

EQUO Series

**Air Flow Station
D6FZ-FGX21**

**Air Flow Sensor
D6FZ-Series**

User's Manual

Introduction

Thank you for purchasing an EQUO Series D6FZ-FGX21 Air Flow Station and D6FZ-Series Air Flow Sensor. This manual describes the information on the functions, performance and usage required to use the Power Sensor Station.

Please observe the following when using the Air Flow Sensor and Air Flow Station:

- This product must be handled by specialists with electrical knowledge.
- Read this User's Manual thoroughly to be familiar with the product beforehand for correct operation.
- Keep this manual for future reference.

Trademarks

- Microsoft and Windows are registered trademarks or trademarks of Microsoft Corporation in the United States and other countries.
- Other company names and product names are registered trademarks or trademarks of each company.

Manual Types and Their Usage

The major contents of the manuals are shown below. Select and read the manual according to your need.

Included Manuals (Print)

Instruction Sheet

Describes the information to ensure the safe and proper use of the product, and information regarding ratings, performance and installation.

Startup Guide

Describes the basic procedures including the package content check, assembly, setting operation, recording operation and data display.

Manuals included in the Utility Disk (PDF data)

User's Manual (This document)

Describes information to ensure the safe and proper use of the product

Describes package content items and detailed procedures for assembly, setting operation, recording operation and data display

Product specifications

Other necessary information required to use the D6FZ-FGX21 Air Flow Station and Air Flow Sensors.

Provided PC Software "User's Manual"

Describes the information on the functions and operation of the provided PC software.

Read and Understand this Manual

Please read and understand this manual before using the products. Please consult your OMRON representative if you have any questions or comments.

Warranty and Limitations of Liability

<WARRANTY>

OMRON's exclusive warranty is that the products are free from defects in materials and workmanship for a period of one year (or other period if specified) from date of sale by OMRON.

OMRON MAKES NO WARRANTY OR REPRESENTATION, EXPRESS OR IMPLIED, REGARDING NON-INFRINGEMENT, MERCHANTABILITY, OR FITNESS FOR PARTICULAR PURPOSE OF THE PRODUCTS. ANY BUYER OR USER ACKNOWLEDGES THAT THE BUYER OR USER ALONE HAS DETERMINED THAT THE PRODUCTS WILL SUITABLY MEET THE REQUIREMENTS OF THEIR INTENDED USE. OMRON DISCLAIMS ALL OTHER WARRANTIES, EXPRESSED OR IMPLIED.

<LIMITATIONS OF LIABILITY>

OMRON SHALL NOT BE RESPONSIBLE FOR SPECIAL, INDIRECT, OR CONSEQUENTIAL DAMAGES, LOSS OF PROFITS OR COMMERCIAL LOSS IN ANY WAY CONNECTED WITH THE PRODUCTS, WHETHER SUCH CLAIM IS BASED ON CONTRACT, WARRANTY, NEGLIGENCE, OR STRICT LIABILITY.

In no event shall the responsibility of OMRON for any act exceed the individual price of the product on which liability is asserted.

IN NO EVENT SHALL OMRON BE RESPONSIBLE FOR WARRANTY, REPAIR, OR OTHER CLAIMS REGARDING THE PRODUCTS UNLESS OMRON'S ANALYSIS CONFIRMS THAT THE PRODUCTS WERE PROPERLY HANDLED, STORED, INSTALLED, AND MAINTAINED AND NOT SUBJECT TO CONTAMINATION, ABUSE, MISUSE, OR INAPPROPRIATE MODIFICATION OR REPAIR.

Application Considerations

<SUITABILITY FOR USE>

OMRON shall not be responsible for conformity with any standards, codes, or regulations that apply to the combination of the products in the customer's application or use of the products.

At the customer's request, OMRON will provide applicable third party certification documents identifying ratings and limitations of use that apply to the products. This information by itself is not sufficient for a complete determination of the suitability of the products in combination with the end product, machine, system, or other application or use.

The following are some examples of applications for which particular attention must be given. This is not intended to be an exhaustive list of all possible uses of the products, nor is it intended to imply that the uses listed may be suitable for the products:

- Outdoor use, uses involving potential chemical contamination or electrical interference, or conditions or uses not described in this manual.
- Nuclear energy control systems, combustion systems, railroad systems, aviation systems, medical equipment, amusement machines, vehicles, safety equipment, and installations subject to separate industry or government regulations.
- Systems, machines, and equipment that could present a risk to life or property.

Please know and observe all prohibitions of use applicable to the products.

NEVER USE THE PRODUCTS FOR AN APPLICATION INVOLVING SERIOUS RISK TO LIFE OR PROPERTY WITHOUT ENSURING THAT THE SYSTEM AS A WHOLE HAS BEEN DESIGNED TO ADDRESS THE RISKS, AND THAT THE OMRON PRODUCTS ARE PROPERLY RATED AND INSTALLED FOR THE INTENDED USE WITHIN THE OVERALL EQUIPMENT OR SYSTEM.

<PROGRAMMABLE PRODUCTS>

OMRON shall not be responsible for the user's programming of a programmable product, or any consequence thereof.

Disclaimers

<CHANGES IN SPECIFICATIONS>

Product specifications and accessories may be changed at any time based on improvements and other reasons.

It is our practice to change model numbers when published ratings or features are changed, or when significant construction changes are made. However, some specifications of the products may be changed without any notice. When in doubt, special model numbers may be assigned to fix or establish key specifications for your application on your request. Please consult with your OMRON representative at any time to confirm actual specifications of purchased products.

<DIMENSIONS AND WEIGHTS>

Dimensions and weights are nominal and are not to be used for manufacturing purposes, even when tolerances are shown.

<ERRORS AND OMISSIONS>

The information in this manual has been carefully checked and is believed to be accurate; however, no responsibility is assumed for clerical, typographical, or proofreading errors, or omissions.

<COPYRIGHT AND COPY PERMISSION>

This manual shall not be copied for sales or promotions without permission.

This manual is protected by copyright and is intended solely for use in conjunction with the product. Please notify us before copying or reproducing this manual in any manner, for any other purpose. If copying or transmitting this document to another, please copy or transmit it in its entirety.

Precautions on Safety

● Meanings of Signal Words







For the safe operation of D6FZ-FGX21 Air Flow Station and D6FZ-Series of Air Flow Sensors and this operation manual indicates the precautions by using the following marks and symbols. The precautions given here contain important information related to safety, and therefore must be observed.

The marks and symbols for the safety precautions are as follows:

 <b style="font-size: 1.2em;">WARNING	<p>Indicates a potentially hazardous situation which, if not avoided, will result in minor or moderate injury, or may result in serious injury or death. Additionally there may be significant property damage.</p>
--	---



 <b style="font-size: 1.2em;">CAUTION	<p>Indicates a potentially hazardous situation which, if not avoided, may result in minor or moderate injury or in property damage.</p>
--	---



● Meaning of Precaution Symbols

	<p>● Mandatory Requirement Indicates a general mandatory requirement.</p>
	<p>● Prohibition Indicates general prohibition.</p>
	<p>● Electric Shock Warning Warns against an electric shock under specific conditions.</p>
	<p>● Prohibition Indicates general prohibition.</p>
	<p>● Explosion Warning Warns against an explosion under specific conditions.</p>
	<p>● Disassembly Prohibition Indicates the possibility of accidents such as an electric shock caused by unit disassembly.</p>

Air Flow Station



•Warning Indications



 WARNING	
The mounting magnets (separately sold) for the product have strong magnetism. If the product is mounted using these magnets, anyone wearing a heart pacemaker must not operate the product; or the product must not be in proximity of such a person.	
This product contains a lithium battery. Serious injury may occur due to fire or explosion. Do not attempt to disassemble the product, deform it by applying pressure, heat it in a high temperature (100°C or more), or burn it for disposal.	

 CAUTION	
Tighten the terminal screws at a recommended torque: 0.69 to 0.88N · m. Make sure that the screws are not slanted away from the center after tightened.	
A minor or moderate injury or property damage may occur due to explosion. Do not use the product in an environment containing an inflammable or explosive gas.	
An electric shock or minor injury as well as fire or unit malfunction may occur. Do not attempt to disassemble, repair or modify the product.	

Air Flow Sensor (D6FZ-Series)

•Warning Indications

 WARNING	
The use of flammable gases may cause explosion. Do not use the product with flammable gases.	
An electric shock may occur. Do not connect to an AC power source.	

 CAUTION	
Injury may occur due to explosion. Flow rate and pressure must be within the range of use.	
<D6FZ-FGT□□□> If water drop, oil, mist and dust flow in the body, it may mismeasurement and destruction. Use clean fluid. Dust and mist can affect the characteristics of Sensor or damage the sensor. Install a filter and mist separator on the upstream tube. Moreover, install an air flow sensor after removing the dust remaining in pipe by something like air blow.	

Precautions for Safe Use

Observe the following precautions to ensure safe operation:

Air Flow Station

- Do not install the product in the places subject to exposure to water, oil, or chemical splashes.
- Do not use the product for the safety circuits in nuclear power or life-critical applications.
- When disposing of the product, treat as industrial waste.
- Do not let the product drop or subject it to a shock, which may cause its damage or malfunction. Use screws to secure the product when mounting it on the wall. Stop using the product if it has been applied with a strong impact.
- When inserting or removing an SD memory card, securely hold the product to prevent it from dropping, which may cause a damage. Do the same when inserting or detaching an alarm output cable or connector.
- Do not bring the product close to magnetic products (e.g. magnetic cards), sensitive electronics equipment (e.g. computers or clocks), when the product is attached with the mounting magnets.
- Small pieces may be chipped off the mounting magnets when they are attracted to the surface. Make sure the pieces do not enter the eyes. Consult a medical doctor if this happens.
- When using the mounting magnets to install the product, take caution not to allow a finger to be caught between the product(s) and the magnetic surface.
- Do not install the product at a high place when using the mounting magnets.
- Apply an appropriate load to the alarm output terminals to prevent possible smoking.
- If liquid crystal leaks due to a damage to the LCD panel, take caution not to allow it to contact your skin, to be inhaled or swallowed. If it has contacted your skin or entered your mouth, seek medical attention.
- Take anti-static electricity measures (e.g. touching grounded metal object) when handling the product.

Air Flow Sensor (D6FZ-Series)

<D6FZ-Series>

- Do not use the power supply that exceeds rated voltage.
- Use a DC power supply unit provided with anti-voltage design (safety extra low voltage circuit) to supply power to the product.
- Do not connect the power supply in reverse.
- Do not short-circuit outputs.
- The attached connection cable is only for Air Flow Station (D6FZ-FGX). Do not connect with other device.
- Do not use the Sensor with any gases or liquids other than specified in this document.
- Be sure to secure the Sensor with the stipulated torque.
- Do not install the Sensor in a location where strong compressive force or tensile force applied to the Sensor.
- Do not attempt to disassemble, repair, or modify this product.
- When disposing of the product, treat as industrial waste.

- Do not let the product drop or subject it to a shock. Stop using the product if it has been applied with a strong impact.
- Don't connect a power supply to RS-485 communications line. There is fear of product damage.
- Fix with only the conduit part when mounting pipe, or the product might damage.

<D6FZ-FGS1000>

- Do not ground Brown colored wire (DC24V). As the enclosure is connected to 0V inside circuit, it is short-circuited with your device FG.
- Be sure to ground Blue colored wire + shield (0V) of single-end wire cable (D6F2-JD□A).

<D6FZ-FGT□□□>

- Don't touch the current plate in the flow channel, or fingers might be injured.
- Connect blue colored wire (0V) with the shield line of a single-end line cable (model D6FZ-JD □ A , sold separately). The shield line and the blue colored wire (0V) is connected inside form D6 FZ-JD □ A.

Precautions for Correct Use

Air Flow Station

1. Avoid installing the product in the following places:

- Places exceeding the rated ambient temperature
- Places exposed to extreme temperature changes (where condensation occurs)
- Places subject to relative humidity exceeding the rated humidity range
- Places subject to corrosive or flammable gases
- Places subject to mist, droplets, coarse particles, fiber, salt, metal dust, or large amount of particles
- Places subject to direct shock or vibration
- Places subject to direct sunlight
- Places subject to exposure to water, oil, or chemical splashes
- Places subject to strong magnetic field or electric field
- Outdoors

2. Wiring

- Wire the product cable separately from high-voltage or power lines. Placing them in the same wiring or the same duct may cause induction, resulting in the product malfunction or damage.
- Make sure that the I/O terminals are inserted or removed with the power turned OFF. Doing this with the power ON may result in a failure.

3. Mounting screw hole

- The screw holes provided on the product are M3 and 4 mm deep. Do not screw deeper than 4 mm, which may damage the product.

4. Do not open the unit rear cover. (No battery terminal is provided.)



Air Flow Sensor (D6FZ-Series)

<D6FZ-Series>

1. Do not install the product in locations subjected to the following conditions:

- Ambient temperature outside the rating
- Ambient humidity outside the rating
- Altitude of 2,000 m or higher above sea level
- Presence of corrosive or flammable gases
- Presence of salt or iron particles
- Direct vibration or shock
- Outdoors or direct sunlight
- Water, oil, or chemical fumes or spray, or mist atmospheres
- Presence of strong magnetic field, electric field or charged object

2. Power Supply and Wiring

- If the power supply line is subject to surges, connect a surge absorber that meets the conditions of the operating environment.
- Be sure to check the polarity before connecting a power supply line/output line. Do not apply over-rated voltage.
- Do not short circuit the power supply when connecting a power supply line.
- Do not use the product with current higher than the rating when connecting an output line.
- Lay the product cable away from any high-voltage cable or power line. If laid in the same conduit or duct, induction noise from them may cause malfunction or breakdown of the product.
- Do not insert or remove a connector, etc. with power supply applied.

3. Installation

- When using analog output or control output, cable length needs to be less than 30 m.
- When using with an Air Flow Station make the power supply voltage 24VDC.
- When using RS-485 communication and cable length is 30 m to 100 m, be sure to ground blue colored wire (0V) and shield.

<D6FZ-FGS1000>

- Do not use the product as scaffolding.
- Take caution not to mount the status indicator downward. Doing so may result in Malfunction.

<D6FZ-FGT□□□>

- Be sure to mount the body horizontally, otherwise the detection accuracy might be worse.
- Don't mount the body facing the control panel downward. Otherwise, the mist and dust in the pipe accumulates and it might cause breakdown.

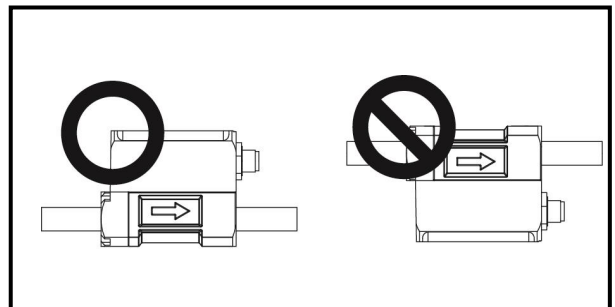
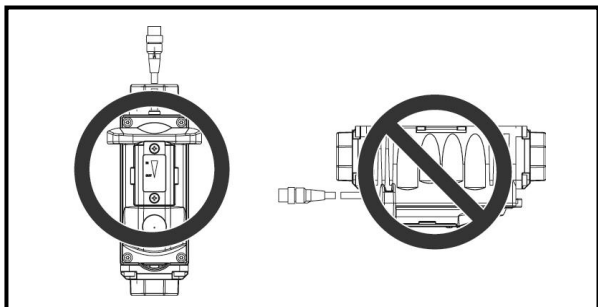

How to Read This Manual

■ Symbols Used in this Manual

Menu items that are displayed on the screen, and windows, dialog boxes and other GUI elements displayed on the PC are indicated enclosed by brackets "[]".

■ Marks Used in this Manual

Important : Indicates essential information on the product operation and functions, which requires special attention or caution.

Note : Shows operational tips or related useful information.

Table of Contents

Introduction	i
Table of Contents	xi
1. Product Overview	1-1
1.1 Features and Functions	1-1
1.2 Configuration	1-3
1.2.1 Single Air Flow Sensor Unit Connection	1-4
1.2.2 Local Connection	1-4
1.2.3 Network Connection.....	1-4
1.3 Multi-point Air Flow Measurement.....	1-5
1.4 Setup and Operation Procedure	1-6
1.4.1 Single Air Flow Sensor Unit Operation	1-6
1.4.2 Standalone Operation	1-7
1.4.3 Operation via Network	1-8
2. Part Name and Function	2-1
2.1 Air Flow Sensor (D6FZ-FGS1000).....	2-1
2.1.1 Display Unit.....	2-1
2.1.2 Control Unit.....	2-2
2.1.3 Input/Output Specifications	2-3
2.2 Air Flow Sensor (D6FZ-FGT□□□)	2-5
2.2.1 Control Panel / Display	2-5
2.2.2 Control panel	2-5
2.2.3 Input/Output Specifications	2-6
2.3 Air Flow Station (D6FZ-FGX21).....	2-7
2.3.1 Display Unit.....	2-8
2.3.2 Control Unit.....	2-9
2.3.3 Input/Output Specifications	2-10
3. Check and Preparation	3-1
3.1 Checking the Package Contents	3-1
3.2 Preparing the Required Items	3-1
3.3 Setting and Installation	3-2
3.3.1 Single Air Flow Sensor Unit Operation	3-2

3.3.2	Standalone Operation Connecting Air Flow Sensors to Air Flow Station	3-4
3.4	Overview of Provided PC Software.....	3-9
3.4.1	Overview	3-9
3.5	Setting the Measurement Conditions	3-10
3.5.1	Settings (FUN Mode Operation)	3-10
3.6	Connecting to Network.....	3-12
3.6.1	Preparation	3-12
3.6.2	Setting Air Flow Station IP Address	3-13
3.6.3	Setting the PC IP Address	3-16
3.6.4	Connecting a LAN Cable	3-25
3.7	Mounting Air Flow Sensor and Air Flow Station	3-25
3.7.1	Mounting Air Flow Sensor	3-25
3.7.2	Mounting Air Flow Station Unit	3-28
3.8	Remotely Setting Air Flow Sensors and Air Flow Station	3-30
4.	Setting (Air Flow Station Operation)	4-1
4.1	Setting Procedure and Operation Modes	4-1
4.2	Settings (FUN Mode Operation).....	4-2
4.2.1	List of Setting Items.....	4-3
4.2.2	Selecting "FUN" Operation Mode.....	4-4
4.2.3	Selecting Items	4-5
4.2.4	Description of Items	4-6
4.2.5	Changing Air Flow Station Set Value	4-14
4.2.6	Changing Air Flow Sensor Set Value	4-16
4.3	Settings (THR Mode Operation)	4-18
4.3.1	List of Setting Items.....	4-19
4.3.2	Selecting Operation Mode.....	4-20
4.3.3	Selecting Items	4-20
4.3.4	Description of Items	4-21
4.3.5	Changing Set Value.....	4-22
5.	Measurement and Recording (Air Flow Station Operation)	5-1
5.1	Overview	5-1
5.2	Selecting Operation Mode	5-1
5.3	Screen Transition in RUN Mode.....	5-2
5.4	Starting/Stopping Recording	5-5
5.4.1	Starting Recording	5-5

5.4.2	Stopping Recording	5-5
5.4.3	Auto backup and restarting record setting.....	5-6
5.5	Outputting File to SD memory card.....	5-6
5.6	Cancelling Alarm	5-6
6.	Appendix	6-1
6.1	Error Display List.....	6-1
6.2	Character Display List.....	6-4
6.3	SD Memory Card Folder Structure	6-6
6.4	Calibration	6-7

1. Product Overview

1.1 Features and Functions

Air Flow Station

(1) Easy Multi-point Data Acquisition

The D6FZ-FGX21 Air Flow Station combined with the D6FZ- Series Air Flow Sensors provides the measurement and recording of air flow, pressure and temperature at multiple points. Individual integrated flow rate values are added to total sums, which can be checked at operation sites. The Air Flow Station can be connected to up to eight Air Flow Sensor units, whose momentary and integrated flow rate values can be independently recorded. Flow rate data acquisition at operation sites now becomes easy, contributing to enhanced energy-saving efficiency.

(2) Recording to an SD Memory Card

The measured data can be recorded in the Air Flow Station (D6FZ-FGX21). Data recorded for approx. four hours at 1 second cycle can be accumulated in the internal memory when a single Air Flow Sensor unit is connected, which enables the Air Flow Station to continue recording even at an emergency network failure. The Air Flow Station allows its data accumulated in the internal memory to be output to an SD memory card in CSV format without stopping measurement, thus making continuous recording for long hours possible. NOTE: The internal memory can store the data continuously recorded for up to minimum approx. 30 minutes (at a recording cycle time of 2 seconds, when eight Air Flow Sensor units are connected). Use an SD memory card for longer time of recording.

(3) Network Connection

The measured values obtained from multiple Air Flow Station units in a network can be acquired to a PC connected via LAN cables by using the provided PC software (Multi Data Viewer Light). The individual Air Flow Station and Air Flow Sensor units can be controlled from the PC to check or change their settings as well as send recording start/stop instruction. (Refer to the provided PC software "User's Manual" for details.)

(4) Graph Display and Data Processing Software (Provided as Standard)

The data output to an SD memory card or recorded to a PC through network connection can be displayed in graphs or processed online by using the provided PC software. The data items in different periods can be combined or multiple Air Flow Station data can be displayed simultaneously side by side on the screen. (Refer to the provided PC software "User's Manual" for details.)

(5) Alarm Output

Alarm output terminals are provided on the Air Flow Station. An alarm is output when the measured air flow rate exceeds the upper limit. This feature provides 'visualization' of the air flow limit, allowing the operator to quickly handle errors.

Air Flow Sensors (D6FZ-Series)

<D6FZ-FGS1000>

(1) Simultaneous Flow Rate/Pressure/Temperature Measurement

Based on ultrasonic measurement, the Air Flow Sensor provides simultaneous measurement of flow rate (momentary flow and integrated flow), pressure and temperature.

(2) Flexible Installation Regardless of Location

The capability of measuring air flow mixed with oil or mist provides the installation at various locations such as behind the curve of a tube.

(3) Analog Output/Pulse Output

The analog output (of standard flow rate/pressure) and pulse output (of integrated flow rate) from Air Flow Sensors are available for an environment where digital communication is not possible.

<D6FZ-FGT□□□>

(1) Easy to detect air leaks

High measurement accuracy of low flow makes compressed air leaks detection easy.

(2) Flexible Installation Regardless of Location

Sensor equipped with a Flow straightener , the installation at various locations such as behind the curve of a tube.

(3) Analog Output/Pulse Output

The analog output (of standard flow rate/pressure) and pulse output (of integrated flow rate) from Air Flow Sensors are available for an environment where digital communication is not possible.

1.2 Configuration

This product can be used in the following three types of configuration.

Single Air Flow Sensor Unit Operation

<D6FZ-FGS1000>

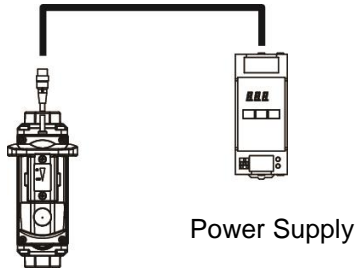

<D6FZ-FGT□□□>

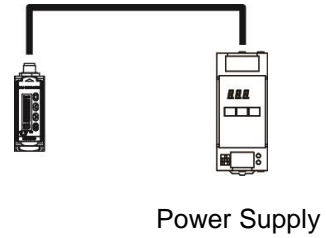

Standalone Operation

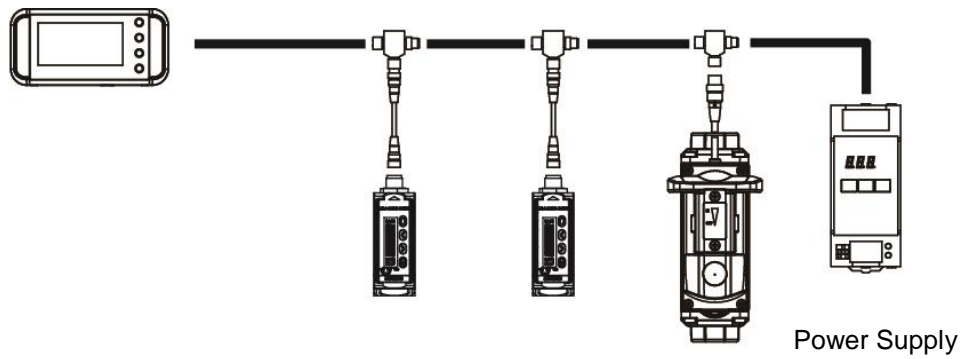

Operation via Network

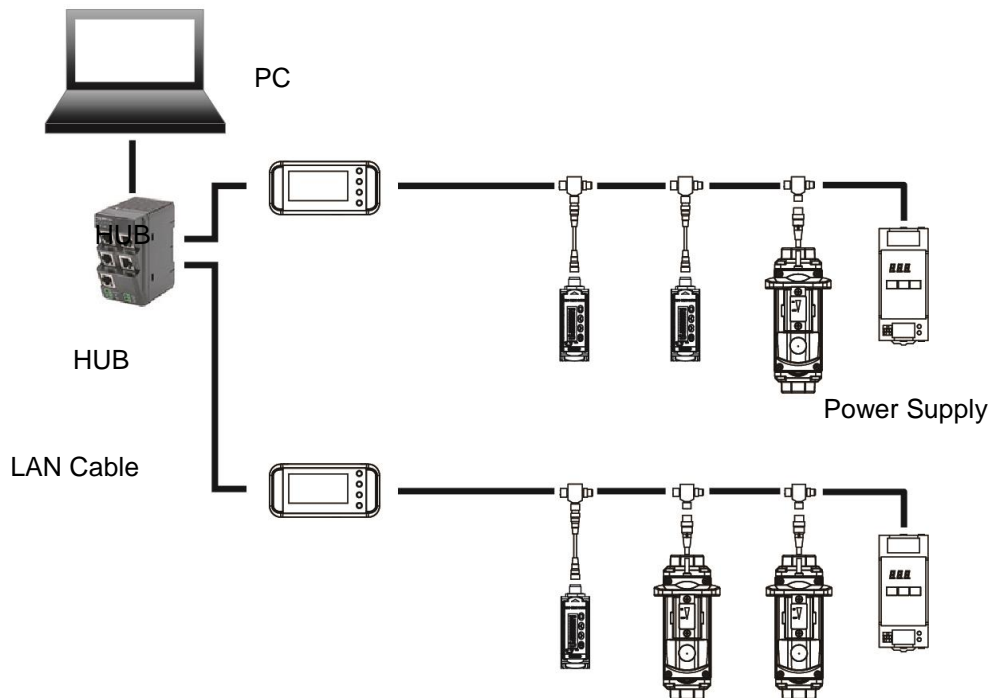

1.2.1 Single Air Flow Sensor Unit Connection

The usage combined with only a single Air Flow Sensor unit.

<D6FZ-FGS1000>

The measured data can be output from two analog systems or a single pulse system. (A T-branch connector cannot be used for analog or pulse output.)

<D6FZ-FGT>

The measured data can be output from analog systems, a single pulse system, Judgment output or unit error output. (A T-branch connector cannot be used for analog, pulse output, Judgment output or unit error output.)

1.2.2 Local Connection

The Air Flow Station can be used standalone without being connected to a network. The measured data is recorded in the internal memory, which can be transferred to a PC via an SD memory card. The recorded data to the SD memory card can be displayed in graphics using the provided PC software. (Refer to the provided PC software "User's Manual" for the details.)

1.2.3 Network Connection

Air Flow Stations can be connected to a PC via network. The following operations are available by using the provided PC software. (Refer to the provided PC software "User's Manual" for details.)

(1) Recording the measurement data on PC

By using the provided PC software, the measurement data can be recorded on PC. The data of the Air Flow Station is displayed on the graph off-line.

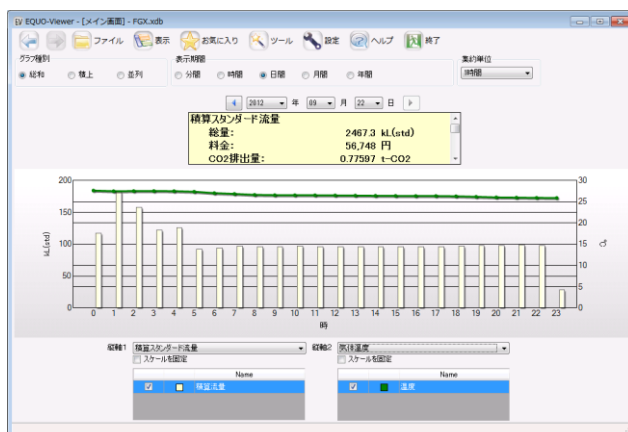

(2) Remote setting / Remote operation via PC

By using the provided PC software, it is possible to set the setting of the air flow station (except the IP address setting), and to operate remotely via computer such as recording Start/Stop.

1.3 Multi-point Air Flow Measurement

- Connecting multiple Air Flow Sensors to an Air Flow Station as the slave units (up to 8 units) can display the momentary flow rate, pressure and temperature values of the individual sensor units. The integrated flow rate of the connected sensor units can be displayed as either of the total sum and the individual rates.
- The air flow rate, pressure and temperature are constantly displayed while the Air Flow Sensor is connected to the Air Flow Station.
- Values measured at multiple points can be logged to a single CSV file record.

※ Pressure and temperature can be measure only by D6FZ-FGS1000.

1.4 Setup and Operation Procedure

1.4.1 Single Air Flow Sensor Unit Operation

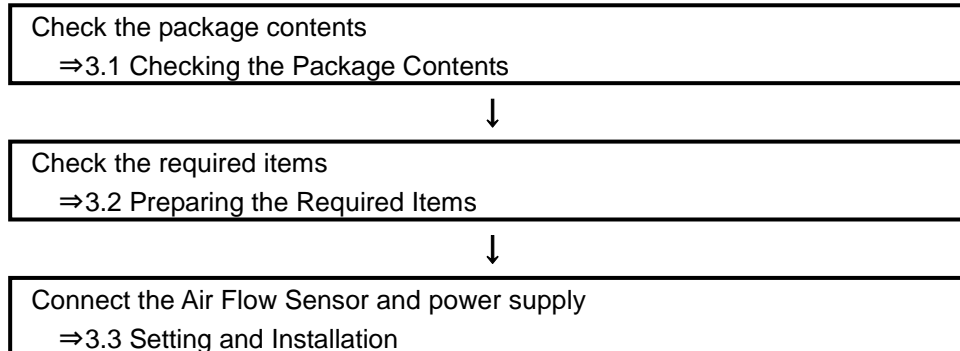

1.4.2 Standalone Operation

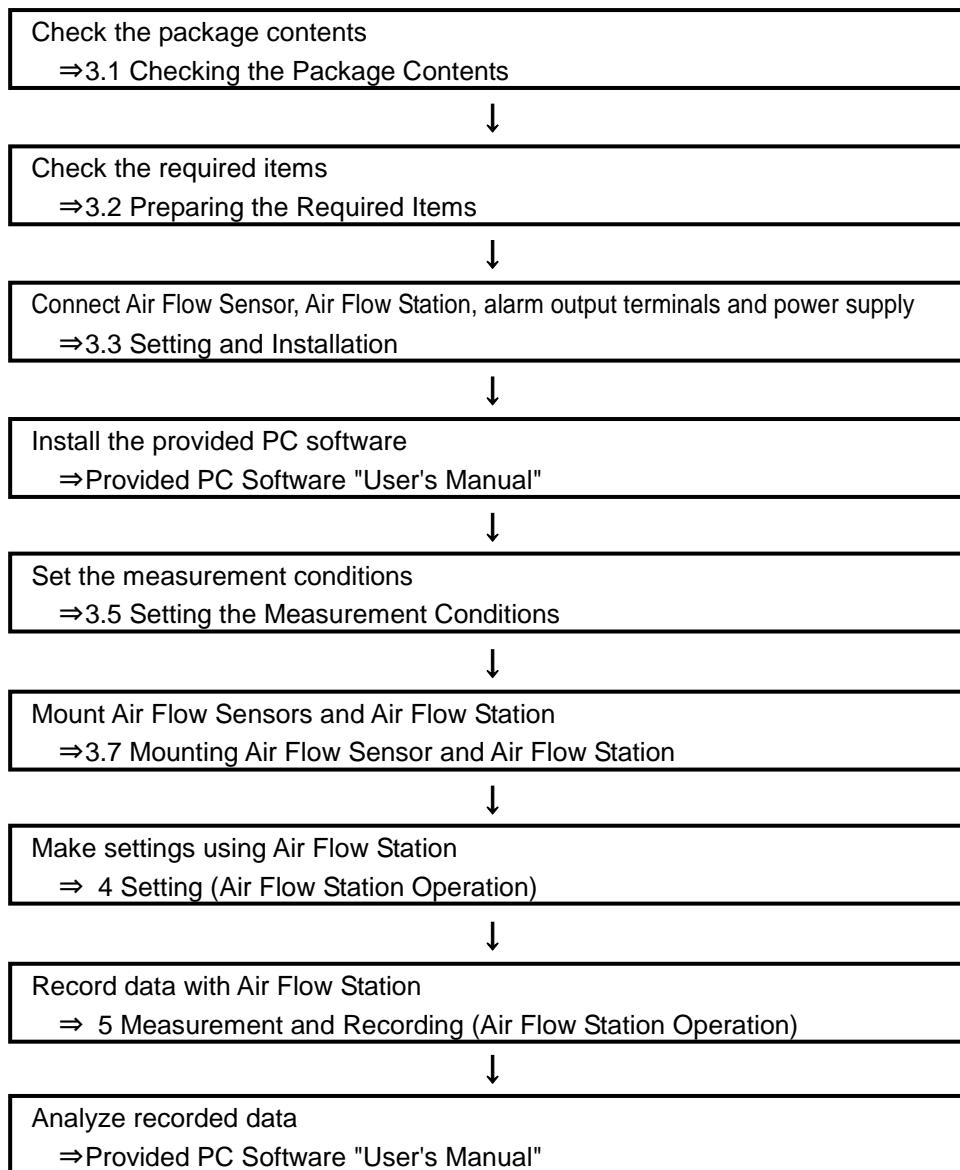

1.4.3 Operation via Network

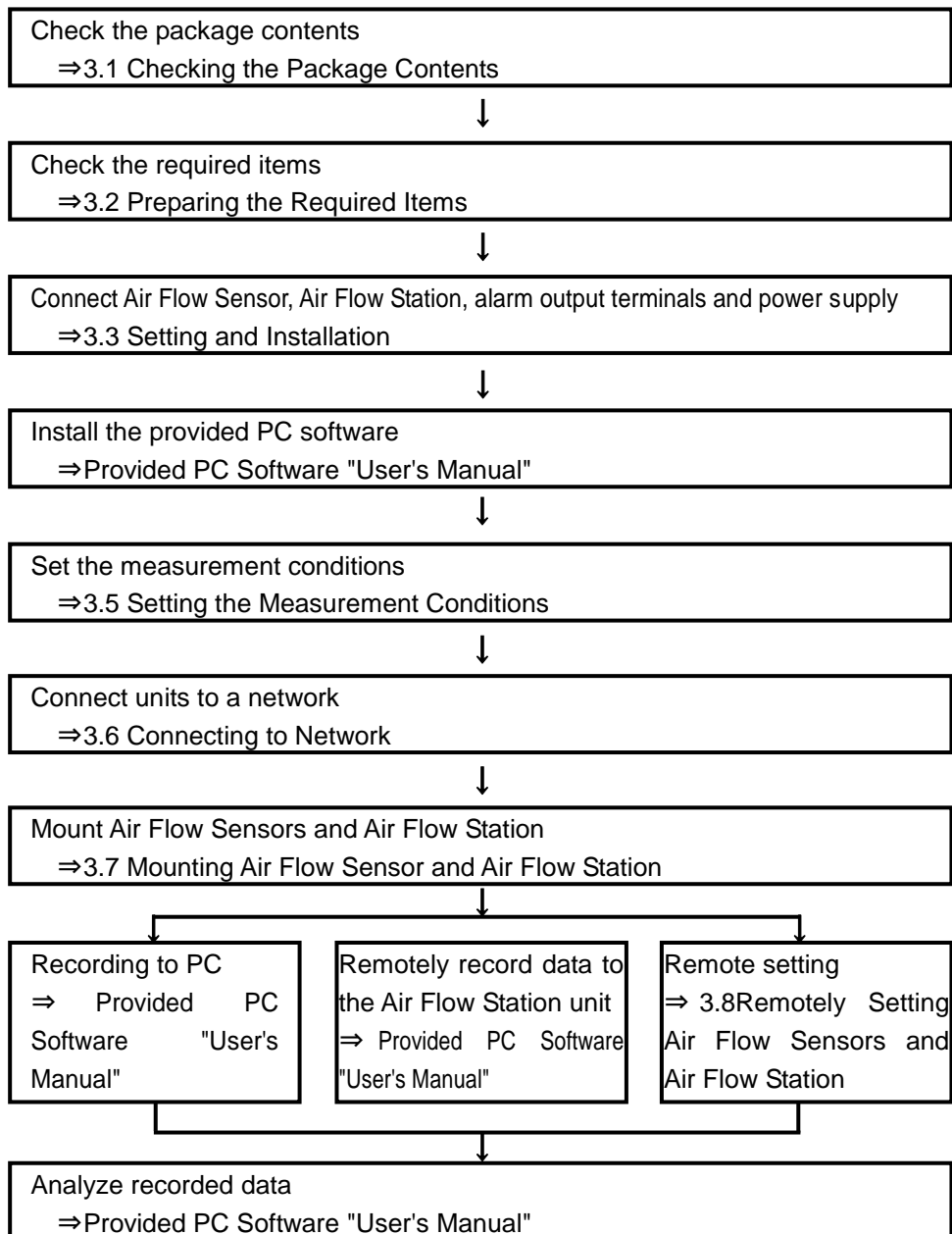

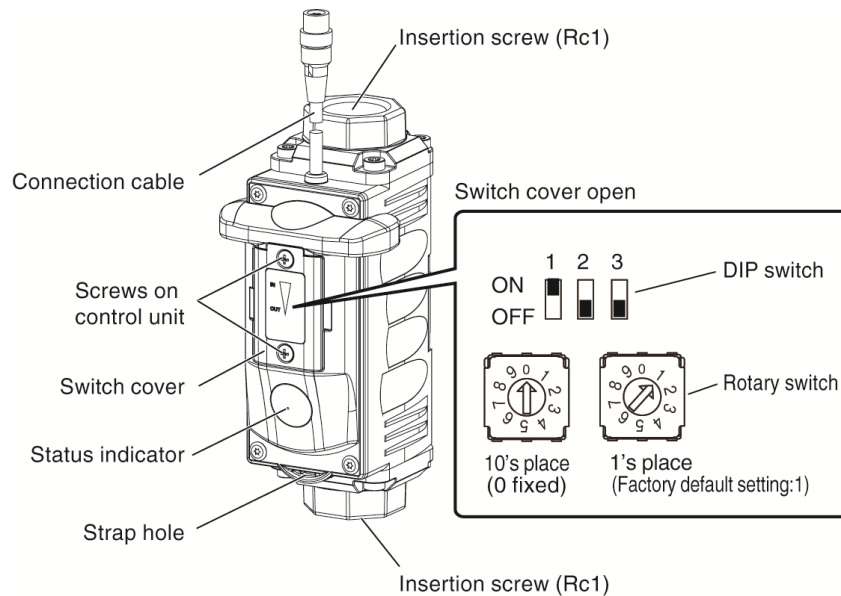

2. Part Name and Function

2.1 Air Flow Sensor (D6FZ-FGS1000)

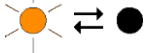

2.1.1 Display Unit

The status indicator colors combined with the indicator status show the air flow status and errors.

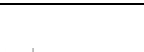
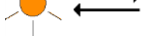
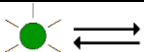
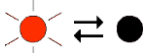
Status Indicator	Definition
 Orange Blink	The air flow rate exceeds the upper threshold. When the factory default: 1000 L/min (std) is exceeded
 Green ON	The air flow rate is normal and between the upper and lower thresholds Factory default setting: 0 to 1000 L/min (std)
 Orange Slow Blink	The air flow is rated between the upper threshold value and zero. This indication does not happen as long as the lower threshold value is set to the factory default (zero).
 Green Slow Blink	The air flow rate is leak detected flow threshold. Factory default setting: 0 L/min (std)
 Deep Orange Blink	The air flows backward.
 Yellow Blink	The unit is in setting process. The status indicator of the relevant Air Flow Sensor blinks when the operation mode of the Air Flow Station enters FUN or THR mode.

NOTE: The above setting is the factory default. The thresholds for LED indicator can be changed using the Air Flow Station.

2.1.2 Control Unit

(1) DIP SW



No.	Definition
1	Communication line terminator setting To use an Air Flow Station (D6FZ-FGX21) or RS-485 communication, turn ON the DIP SW No. 1 of the termination Air Flow Sensor unit in the multi-drop connection. (Factory default setting: ON)
2	Fixed to OFF (Only used for maintenance. Do not turn it ON)
3	Default communication setting Use this to reset the settings when changes cannot be tracked after setting changes. (Factory default setting: OFF)

Important

DIP SW settings are applied after the unit is reset.

(2) Rotary SW

Used to specify the IDs of the Air Flow Sensors connected to the Air Flow Station. The positions from 1 to 8 can be assigned. The ID numbers must be assigned in the ascending order sequentially without skipping any number.

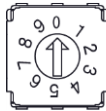

10's Place

(0: Fixed)



1's Place

(Factory default setting: 1)

Important

- Rotary SW settings are applied after the unit is reset.
- 1's Place is available 1 to 8, don't set the ID to 0 and 9.

2.1.3 Input/Output Specifications

(1) Breakout Cable Wires Color Code (D6FZ-JD□A)

The following shows the specifications of the breakout cable connected to the cable connector socket of an Air Flow Sensor unit.

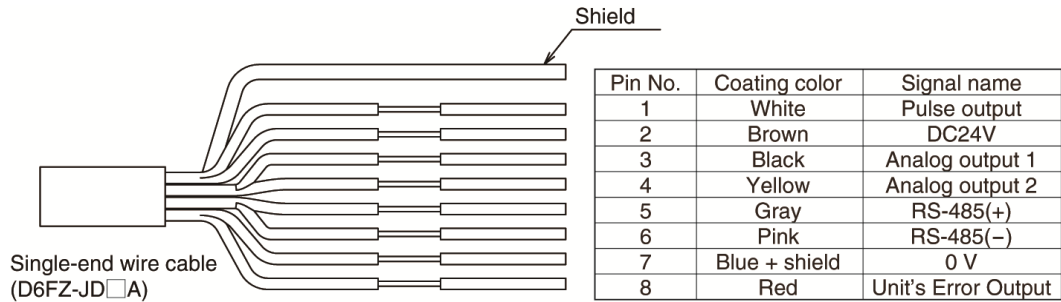

(2) Analog Output

Analog Output 1 and Analog Output 2 are available for single Air Flow Sensor operation. The specifications are shown below:

Output method		Source current (4-20 mA) method
Output accuracy		±0.1 mA (Except for measurement accuracy)
Load resistance		Max. 270 Ω
Output detail (*)	Analog Output 1	Standard Flow Rate (L/min (std)) Full-Scale Flow Rate: 1000 L/min (std) (*) 0 L/min(std): 4 mA 1000 L/min(std): 20 mA (*)
	Analog Output 2	Pressure (kPa) Full-Scale: 1000kPa (1MPa) 0Pa: 4 mA 1Mpa: 20 mA

(*) Can be changed by the D6FZ-FGX21 Air Flow Station.

(3) Pulse Output/Unit Error Output

Pulse Output and Unit Error Output are available for single Air Flow Sensor operation. The specifications are shown below:

Output method		Nch open drain output
Output Stage Circuit Diagram		
Max. rated voltage		24V DC
Max. rated current		50 mA
Residual voltage		Max. 1.5 V
Leakage current		Max. 50 μ A
Pulse Output	Output detail	Outputs the measured standard flow rate in the corresponding unit pulse.
	Output unit	1, 10 (Factory default), 100, 1000L/P (*) The pulse output inverts when the half amount of specified flow rate passes. (E.g. The output inverts at every 5 L is passed, if the rate is specified to 10 L/P.) However, if the frequency increases, the duty may fluctuate by 20 to 80%.
Unit error output	Output detail	Turns ON the output when any of the errors below occurs.
	Detection item	Memory error Ultrasonic wave measurement error Pressure measurement error Temperature measurement error Power supply voltage drop detection

(*) Can be changed by the D6FZ-FGX21 Air Flow Station.

2.2 Air Flow Sensor (D6FZ-FGT□□□)

2.2.1 Control Panel / Display

Control panel(Enlarged)

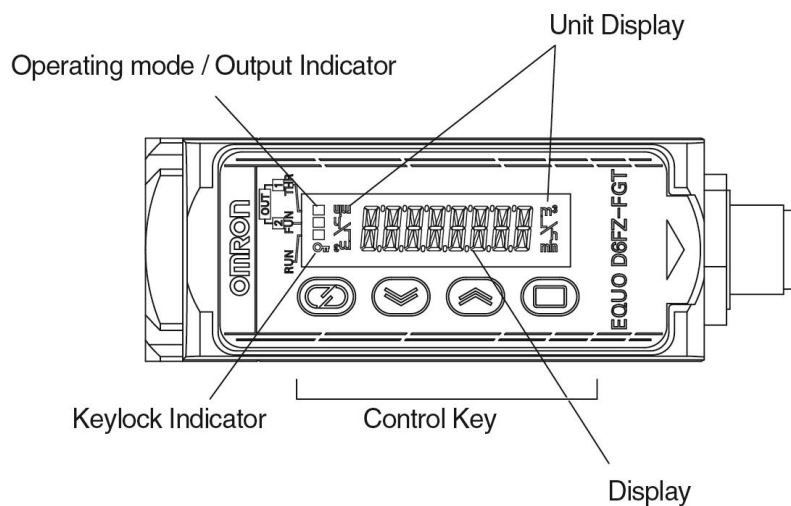

Indicator	Operating mode		
	RUN	FUN	THR
THR / OUT1 ^(*1)	On / Off ^(*2)	Off	Blink
FUN / OUT2 ^(*1)	On / Off ^(*2)	Blink	Off
RUN	On	Off	Off



(*1) In RUN mode, THR Indicator is assigned OUT1, FUN Indicator is assigned OUT2.

(*2) Indicator is turned on according to output function and threshold.

Set threshold value by THR mode and output function allocation by FUN mode.

2.2.2 Control panel

(1) Operation Key

Name	Function
MODE Key 	Switches operating modes (RUN/FUN/THR)
	Sets / Resets Key lock mode (Holding* in RUN-mode)
	Cancels settings (In FUN-mode/ THR-mode)
SELECTION Key 	Selects setting items
	Switches displayed contents
	Changes the setting value(In FUN-mode / THR-mode, High-speed changing by holding* key)
	Display upside down(Holding* key in RUN-mode)
SET Key 	Confirms the setting value
	Sets / Resets zero adjust (Holding* in RUN-mode)
	Sets auto-teaching function(Holding* in THR-mode)

(*) Holding : pressing key continuously for 3 seconds

2.2.3 Input/Output Specifications

(1) Breakout Cable Wires Color Code (D6FZ-JD□A)

The following shows the specifications of the breakout cable connected to the cable connector socket of an Air Flow Sensor unit.

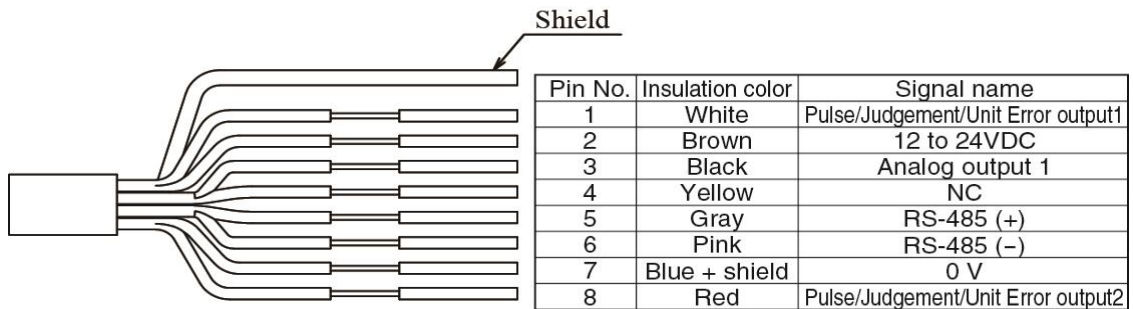

(2) Linear Output

Output : Current output (4 to 20 mA)

Load resistance: 300 max.

Output content: Momentary flow

Analog output	D6FZ-FGT200	D6FZ-FGT500
4mA	0L/min	0L/min
20mA	200L/min	500L/min

(3) ON/OFF Output

Output method	NPN Open collector output
Output stage circuit diagram	
Load power supply voltage	26.4VDC max.
Load current	50mA max. (Residual voltage 2V max.)
Output mode	Pulse output (Pulse width : Approx. 50ms) Judgment output Unit error output

(*)OUT1/OUT2 can be set for any output mode in FUN mode settings.

2.3 Air Flow Station (D6FZ-FGX21)

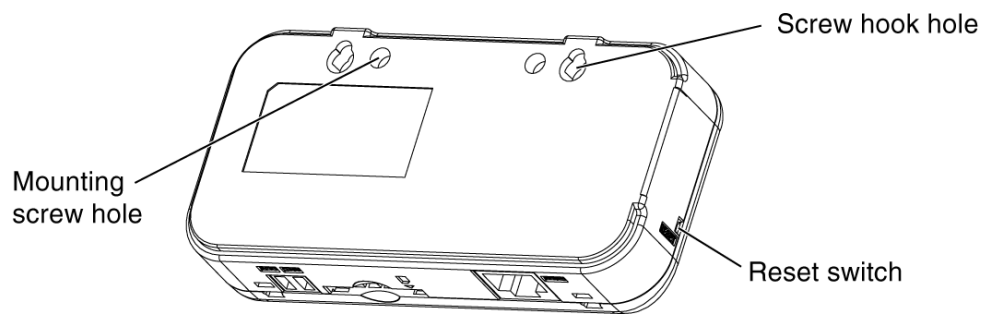
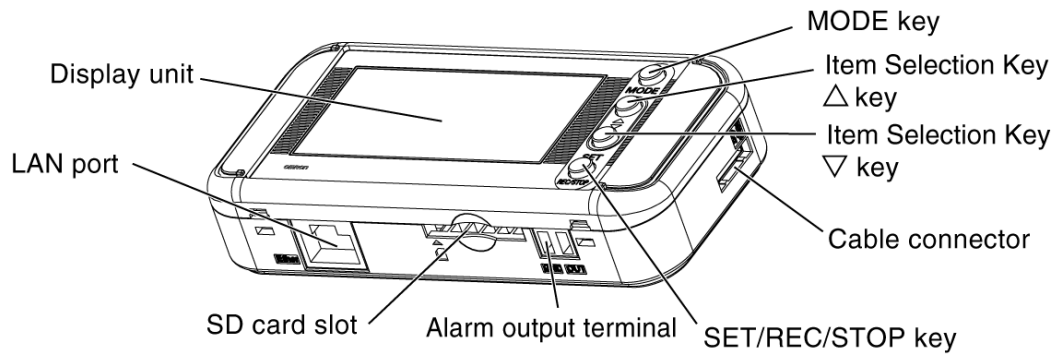

2.3.1 Display Unit



Display Unit

Indicator Definition

Display	Definition/Function (When Displayed)
	Communication via LAN cable is in process.
LAN	A LAN cable is connected and network communication is ready.
REC	Data is being recorded in the internal memory.
SD	An SD memory card is inserted. Blinking: The SD memory card is being accessed.
ALM	Any of connected Air Flow Sensors has exceeded the specified upper or lower threshold.
RUN	The unit is currently operating in RUN mode.
FUN	The unit is currently operating in FUN mode.
THR	The unit is currently operating in THR mode.

"Character Display List" in the last chapter for the definitions of alphabetical, numeric and principal message displays.

2.3.2 Control Unit

(1) Control Key

Name	Function
MODE Key	Switches the operation mode. Resets an alarm or error (Long press). Cancels the setting before applying it.
Item Selection Key (△ Key)	Moves the setting items (Upward). Switches the display. Changes the setting value (Incremental). Sequentially switches the Air Flow Sensor IDs (Long press).
Item Selection Key (▽ Key)	Moves the setting items (Downward). Switches the display. Changes the setting value (Decremental).
SET/REC/STOP Key	Applies the setting value or changes. Starts/stops recording (Long press). Saves the recorded data to the SD memory card.

(2) Reset Switch

The reset switch is provided inside the aperture on the left side of the Air Flow Station unit. Used when an SD memory card is not available when recording stops, or when error recovery cannot be made. Use a thin-tipped object (insulator) such as a pen to press the switch. The unit resets itself.

Do not touch the front keys when the unit is in reset process, until the air flow rate is displayed.

Reset operation does not initialize the settings made on the unit.

(3) Inserting/Removing SD memory card

The Air Flow Station provides an SD memory card slot for SD memory card operation such as writing the measured data recorded in the internal memory to the card, and writing/reading the setting data to/from the card.

Important

- Secure the unit firmly when inserting/removing an SD memory card. It is essential especially when the unit is mounted using the screw hook holes. If the card is inserted / removed without securing the unit, the unit may be detached from the hooks and drop on the floor, damaging itself.
- Do not remove the SD memory card when the "SD" on the display unit is blinking. Doing so may destroy the data in the SD memory card.
- Do not touch the metal terminal of the SD memory card.
- Make sure that the SD memory card does not bend.
- Avoid static electricity when inserting/removing an SD memory card.
- Do not enable the write-protection of the SD memory card.

<Inserting SD memory card>

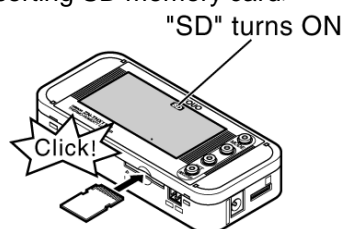

(*)

- (1) Insert an SD memory card into the SD memory card slot with the metal terminal facing up.
- (2) Push the card inward until it clicks.
- (3) "SD" appears on the display.

<Removing the SD Memory Card>

- (1) Push the inserted SD memory card inward until it clicks.
- (2) Stop pushing and let the card pops out. Be careful not to drop it.
- (3) "SD" on the display disappears.

2.3.3 Input/Output Specifications

(1) Alarm Output

<Alarm Output Terminal>

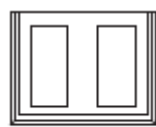

(1) OUT

Outputs the results allocated in THR mode.

(2) GND

A common terminal.



The terminal names are inscribed on the unit.

Use the provided alarm output connector for wiring.

<Output Specifications>

External Power Supply Voltage	DC12 ~ 24 V $\pm 10\%$
Load Current	Max. 45 mA
ON Residual Voltage	Max. 1.2 V
OFF Leakage Current	Max. 0.1 mA
Internal Circuit Diagram	

Important

- Do not connect the external power supply directly between OUT and GND.
- Be sure to connect a load.

3. Check and Preparation

3.1 Checking the Package Contents

This product package includes the following items:

● **Air Flow Station (D6FZ-FGX21)**

<input type="checkbox"/> Air Flow Station Main Unit	1
<input type="checkbox"/> Connection Cable	1
<input type="checkbox"/> Alarm Output Connector	1
<input type="checkbox"/> Utility Disk (CD-ROM)	1
<input type="checkbox"/> Instruction Sheet	1
<input type="checkbox"/> Startup Guide	1

● **Air Flow Sensor (D6FZ-FGS1000)**

<input type="checkbox"/> Air Flow Sensor Main Unit	1
<input type="checkbox"/> Instruction Sheet	1

3.2 Preparing the Required Items

The following items are required to use this product.

(1) Common

<input type="checkbox"/> Power Supply: 24VDC (Recommended model: OMRON S8VS-09024BE)	
<input type="checkbox"/> T-Branch Connector: D6FZ-FC02	
<input type="checkbox"/> Double-Sided Connector Cable: D6FZ-JD□B	
<input type="checkbox"/> PC (personal computer) for the provided software	1
<input type="checkbox"/> SD Memory Card (SDHC compatible)	1 (Recommended model: HMC-SD291)

(2) Network Connection

<input type="checkbox"/> LAN Cable (10BASE-T or 100BASE-TX; Safety Category 5e or higher; Straight Type)	
<input type="checkbox"/> LAN Connection HUB (for 10BASE-T or 100BASE-TX)	

Note

Generally, Air Flow Station units should be connected to a PC via a HUB.

3.3 Setting and Installation

3.3.1 Single Air Flow Sensor Unit Operation

(1) Outputting Analog Signals

This section describes the Analog Output/Analog Output/Unit Error Output connection.

- (1) Connect the connector of the breakout cable (D6FZ-JD□A) to the cable connector socket of the Air Flow Sensor.

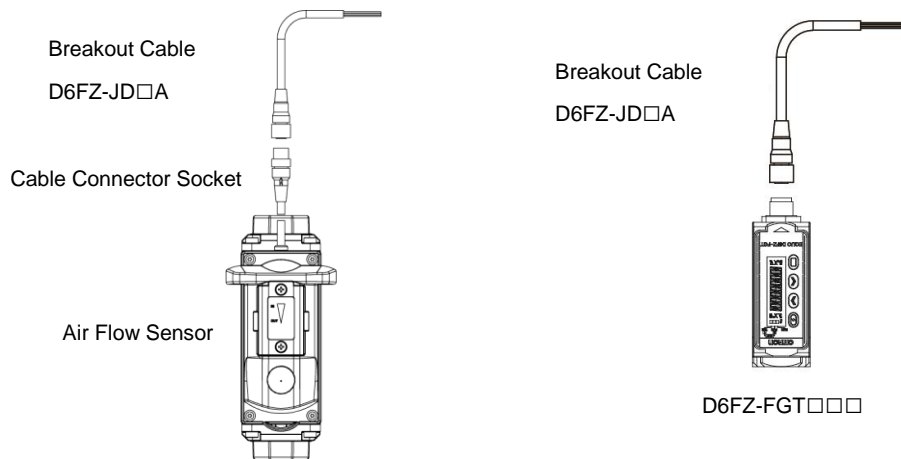

- (2) Connect the following breakout cable wires to the upstream unit as required.

<D6FZ-FGS1000>

- Analog Output 1: Black (Pin No. 3)
 Analog Output 2: Yellow (Pin No. 4)
 Pulse Output: White (Pin No. 1)
 Unit Error Output: Red (Pin No. 8)

<D6FZ-FGT□□□>

- Analog Output 1: Black (Pin No. 3)
 Pulse/Judgment/Unit Error Output: White (Pin No. 1)
 Pulse/Judgment/Unit Error Output: Red (Pin No. 8)

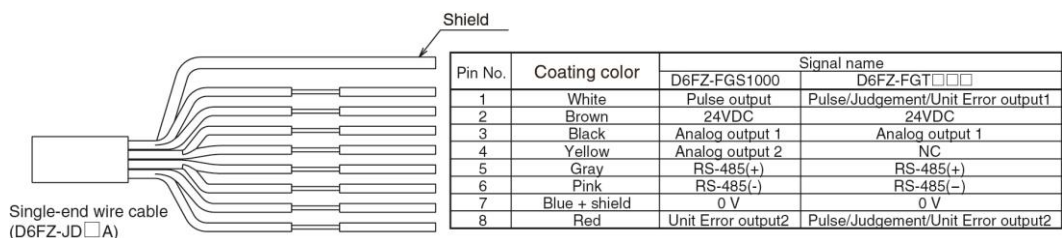

Note

Refer to "2.1.3 Input/Output Specifications" for the Analog Output, Pulse Output and Unit Error Output specifications.

(2) Connecting to Power Supply

Connect the breakout cable (D6FZ-JD□A) to the power supply.

Connect the blue wire (Pin No. 7) to 0V terminal and the brown wire (Pin No. 2) of the breakout cable to the DC24 V terminal.

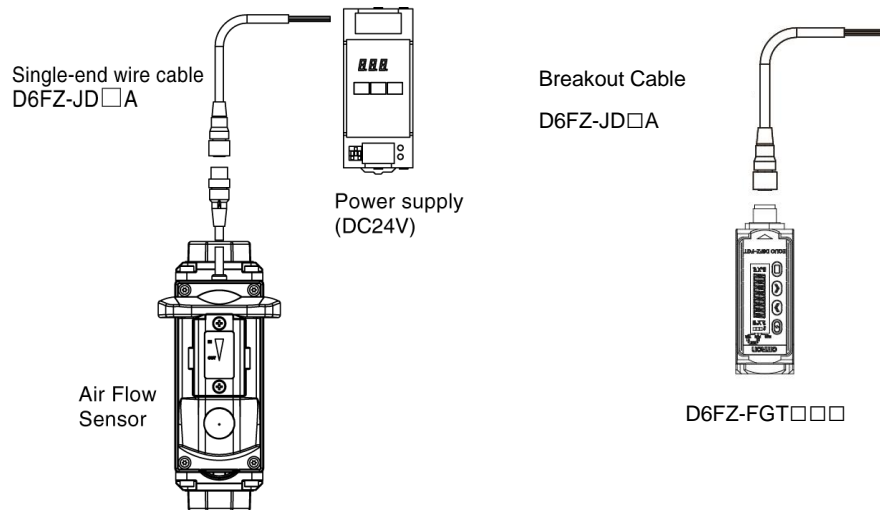

Note

- Refer to the manual of the power supply to connect for the connection procedure.
- The Air Flow Sensor unit does not have a power switch. The unit starts operation immediately when the power is supplied.

3.3.2 Standalone Operation Connecting Air Flow Sensors to Air Flow Station

(1) Air Flow Sensor Setting

Set the Unit No. and Termination resistor of the Air Flow Sensor unit. Up to 8 Air Flow Sensor units can be connected to an Air Flow Station, and it is possible to use D6FZ-FGS1000 and D6FZ-FGT□□□ concurrently.

- Set Unit No. from 01 in sequence.
- When more than one sensor is connected with Air Flow Station, communication terminator of the last sensor must be ON.

< D6FZ-FGS1000 >

This section shows the example of setting five Air Flow Sensor units.

(1) Open the switch cover by removing the screws on the Air Flow Sensor unit.

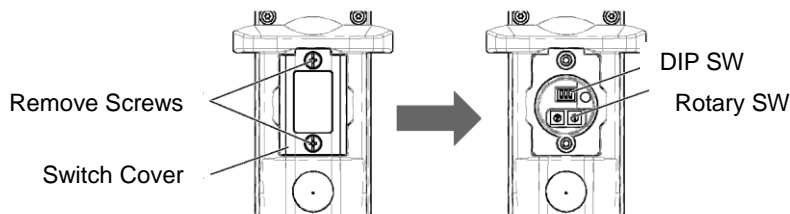

(2) Make settings on the 1st to 4th units.

DIP SW: Set the communication terminator (No. 1) to OFF on all the four units.

See the figure below.

Rotary SW: Assign ID numbers from 01 to 04.

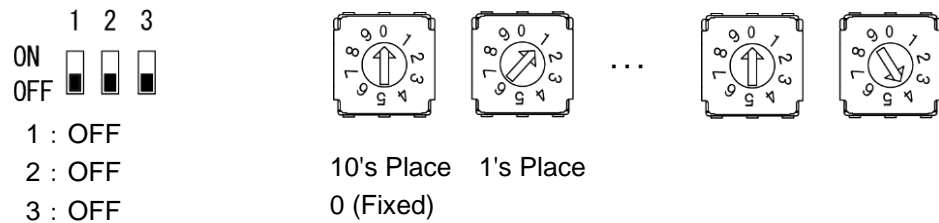

(3) Make settings on the 5th unit (termination).

DIP SW: Set the communication terminator (No. 1) to ON.

Rotary SW: Assign the ID to "05".

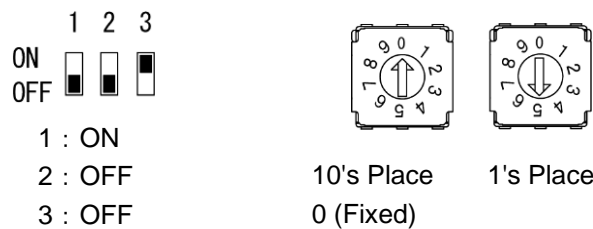

Important

DIP SW and rotary SW settings are applied after the unit is reset.

< D6FZ-FGT□□□ >

By the key operation of the Air Flow Sensor, it is possible to set the Unit No. and Termination resister.

The Unit No. and Termination resister is set in the FUN mode on D6FZ-FGT□□□.

(1) Setting of the communication setting

In order to set communication setting, display the communication setting in FUN mode.

[1] Press MODE Key and select FUN mode.

[2] Press SELECTION Key (UP - DOWN Key) until "SER" is displayed.

[3] Then Press SET Key, Press SELECTION Key until "DISP" is displayed.

And press SET key again.

(2) Setting of the Unit No.

[1] Select FUN mode by MODE Key.

[2] Press SELECTION Key until "U.No. 01" is displayed. Then Press SET Key.

[3] Press SELECTION Key and set the Unit No. (01 to 08). Then Press SET Key.

(3) Setting of the Termination resister

[1] Select FUN mode by MODE Key

[2] Press SELECTION Key until "TER ON" is displayed. Then Press SET Key.

[3] Press SET Key, and press SELECTION Key until "ON" is displayed.

Then Press SET Key.

(3) Connect an Air Flow Sensor unit to a T-branch connectors with the double-sided connector cable (D6FZ-JD□B).

(4) In the same way, connect other Air Flow Sensor units using double-sided connector cables and T-branch connectors.

(3) Using Alarm Function

Use the provided alarm output connector to connect the OUT and GND alarm output terminals to the load according to the output specifications. (Refer to "2.3.3 Input/Output Specifications")

(4) Connecting to Power Supply

Connect the power supply to the T-branch connector to supply power to the Air Flow Sensor and Air Flow Station units.

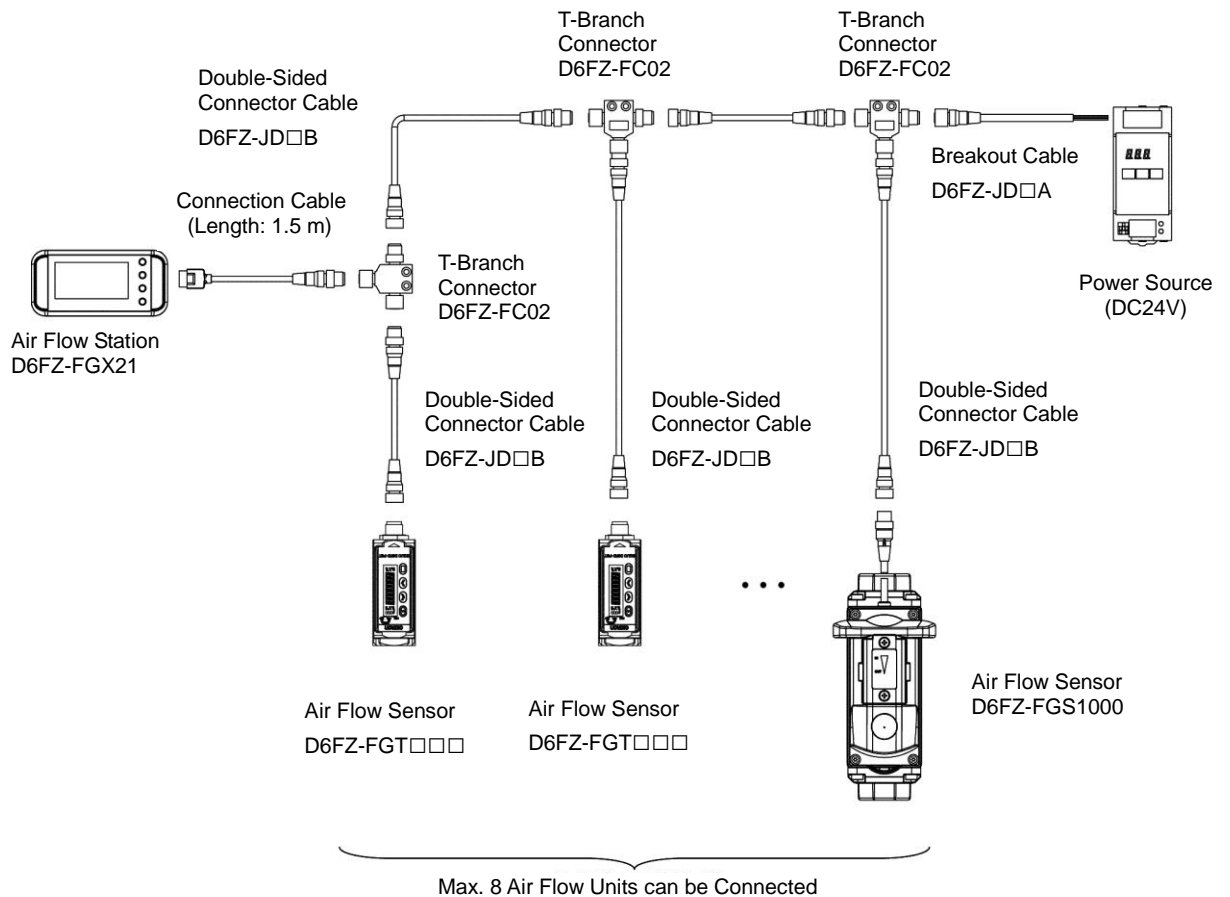

(1) Connect the breakout cable (D6FZ-JD□A) to the power supply.
Connect the blue wire (Pin No. 7) to 0V and the brown wire (Pin No. 2) of the breakout cable to DC24V terminals.

Note

Refer to the manual of the power supply to connect for the connection procedure.

(2) Connect the breakout cable connector to the T-branch connector.

Note

- Air Flow Sensor and Air Flow Station units do not have a power switch. They start operation immediately when the power is supplied.
- Be sure to stop the power supply to change the number of the connected Air Flow Sensor units.

(5) Checking Operation

When the power is supplied, the type name and version are displayed on the display section for a while. The air flow rate information appears on the display, after the unit checks the connection with Air Flow Sensor units.

Press ∇ or \triangle keys to change the display while the "RUN" indicator at the bottom of the display is ON.

(Refer to "5.3 Screen Transition in RUN Mode")

Important

- Do not touch any front keys until the air flow rate appears on the display after the power is supplied.
- 5 seconds or more waiting time is required until the air flow rate information appears, since the Air Flow Sensor and Air Flow Station require time to start up.
- The "ALLOK" indication appears when the unit normally recognizes all the connected Air Flow Sensor units. If the connection is not normally recognized, investigate the cause by checking wirings, DIP SW setting, ID setting, the number of the connected Air Flow Station units, or other related issues.
- If a communication failure such as "no response" occurs on multiple Air Flow Sensor units, after checking the connected unit, the unit with the smallest ID is displayed as "NGnn" ("nn" stands for the Air Flow Sensor ID).
- The Air Flow Station factory default setting of the number of connected Air Flow Sensor units is set to "one". To change the number of units, refer to "3.5 Setting the Measurement Conditions".
- When operating D6FZ-FGT□□□ by the key, select RUN mode on the Air Flow Station. If the Air Flow Station is in FUN-mode or THR-mode, D6FZ-FGT□□□'s key operations are not available and D6FZ-FGT□□□'s main display shows "REMOTE".
- When setting the Air Flow Station in FUN-mode and THR-mode, be sure that this product is in RUN-mode. If this product is set in FUN-mode or THR-mode, "REMOTE" is not displayed and "Error" is displayed on the Air Flow Station.
- In order to cancel the Error, press the MODE key for more than 3 seconds. And change settings, set D6FZ-FGT□□□ in RUN mode and then set the Air Flow sensor in RUN mode.

3.4 Overview of Provided PC Software

3.4.1 Overview

This product provides PC software, which consists of the following functions. Refer to the software's "User's Manual" for details.

- The tool provides Air Flow Station and Air Flow Sensor operations and settings remotely from the PC connected to the Air Flow Station unit.
- Measured values on Air Flow Stations can be recorded to and displayed to the PC via network.

- The tool can display the data recorded with the PC software or Air Flow Station units.
- The tool also provides simple data analysis (summation/consolidation/comparison).

3.5 Setting the Measurement Conditions

Specify the number of Air Flow Sensor units to be connected to the Air Flow Station.

Note

Refer to the sections below for details on messages displayed on the display unit and operational key functions.

Refer to "2.1.1 Display Unit", "2.1.2 Control Unit", and "4.2

3.5.1 Settings (FUN Mode Operation)

(1) Switching to "FUN" Mode

"FUN" mode should be entered for setting measurement conditions. Press the MODE key until the "FUN" indicator at the right of the display starts blinking.

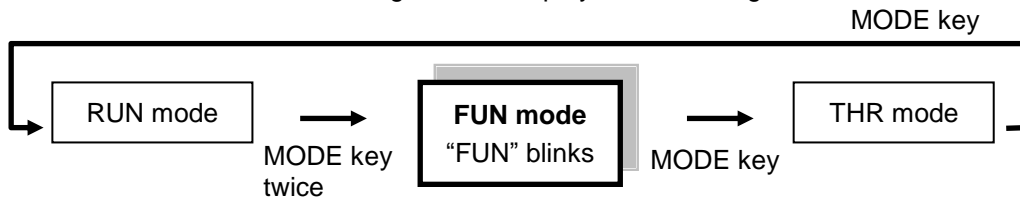

(2) Setting UNIT (the Number) of Air Flow Sensor Units to be Connected

The following shows the operation to set UNIT to "5".

Display (Upper/Lower)	Operation
CYCLE 1s ("FUN" Blinking)	Press the ∇ or Δ key until "UNIT" appears at the upper row on the display.
↓ ∇ or Δ Key	
UNIT 1	The default number of Air Flow Sensor units appears at the lower row. Press the SET/REC/STOP key.
↓ SET/REC/STOP Key	
UNIT 1 ↑ Blinking	The numeral at the lower row starts blinking. Press the ∇ or Δ key to set "5".
↓ ∇ or Δ Key	
UNIT 5 ↑ Blinking	"5" is applied to UNIT by pressing the SET/REC/STOP key.
↓ SET/REC/STOP Key	
UNIT 5	The setting is complete when blinking at the lower row stops.

Note

After the value is applied, the unit restarts when the MODE key is pressed twice and FUN mode is switched to THR mode.

(3) Data Acquisition Cycle (CYCLE) Setting

- The factory default setting of the data acquisition cycle (CYCLE) is 1 second. Measured values on four sensor units (eight when the cycle is 2 seconds or longer) can be updated at this interval.
- Change the data acquisition cycle according to the number of units to connect or the characteristics of the measurement target.

3.6 Connecting to Network

Network settings are required on the Air Flow Station units to be connected to a network. Connect the LAN cables after completing the network settings on the Air Flow Station units.

Important

- A full understanding of network is required to connect Air Flow Stations to a network.
- Establish a dedicated network for connecting Air Flow Station units to a network.
- Connection to an in-house network or an existing network requires caution, since specific restrictions or rules may have been applied to the IP address management. Consult your network administrator. In case that such a network is used, OMRON cannot guarantee the performance of the Air Flow Station units and the provided PC software.

3.6.1 Preparation

Define the IP addresses and subnet masks to use before establishing network connection.

Setting Example

Air Flow Station IP Address	(Unit 1) 192.168.0.20 (Factory default) (Unit 2) 192.168.0.21
PC IP Address	192.168.0.100
Subnet Mask	255.255.255.0 (Factory default)

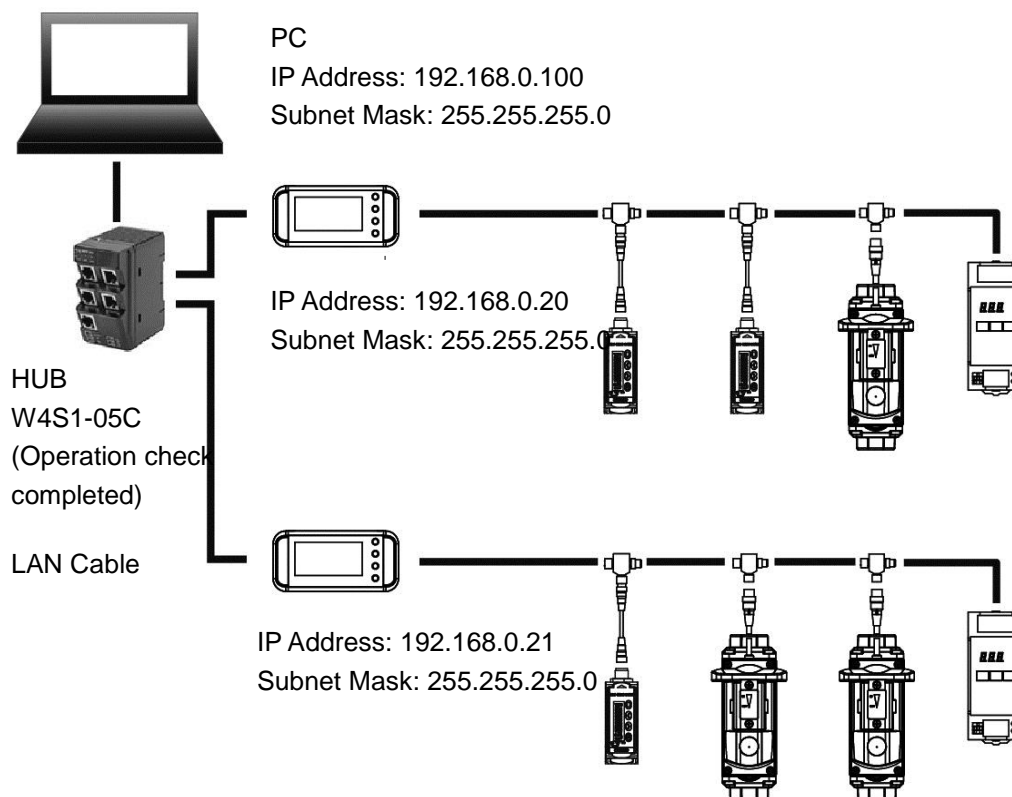

Note

- Air Flow Station units are assigned by the IP address: 192.168.0.20, and subnet mask: 255.255.255.0 as the factory defaults.
- The IP addresses of Air Flow Station units and the PC must be individually unique and must not overlap one another in the network. In the example above, Air Flow Station Unit 2 is assigned with "192.168.0.21", the PC, "192.168.0.100", changing the fourth value (segment) of the IP address of the Air Flow Station Unit 1, in order to distinguish among the units connected.
- Set the same subnet mask value to both the Air Flow Station units and PC to be connected in the network.
- To change the subnet mask, contact your network administrator.
If the subnet mask is changed from 255.255.255.0, the fourth segment of the IP addresses of the Air Flow Station units and PC in the network still must be distinguished from one another.
- The setting range of the individual segments of IP address and subnet mask is 0 to 255.

3.6.2 Setting Air Flow Station IP Address

This section explains the procedure to set the IP address for Air Flow Station Unit 2 (Example: Change the factory default "192.168.0.20" to "192.168.0.21").

Note

Refer to the sections "2.1 Display Unit" and "2.2 Control Unit" for details on messages displayed on the display unit and operational key functions.

(1) Switching to "FUN" Mode

To change the IP address, press the MODE key until the "FUN" indicator at the right of the display starts blinking.

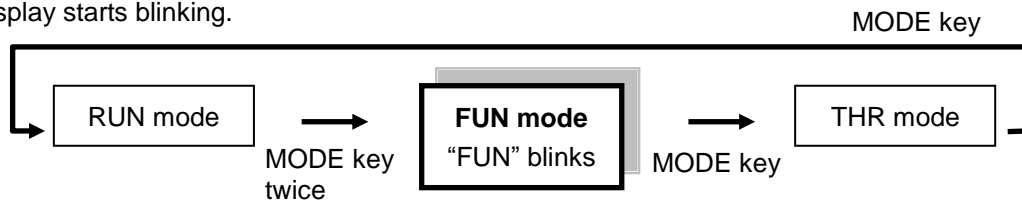

(2) Setting ETC and IP to "DISP"

Display (Upper/Lower)	Operation
CYCLE 1s ("FUN" Blinking)	Press the ▽ or △ key until "ETC" appears at the upper row on the display.
↓▽ or △ Key	
ETC OFF	Press the SET/REC/STOP key. "OFF" at the lower row starts blinking.
↓SET/REC/STOP Key	
ETC OFF ↑Blinking	Press the ▽ or △ key to display "DISP".
↓▽ or △ Key	
ETC DISP ↑Blinking	Press the SET/REC/STOP key to apply "DISP". Blinking stops.
↓SET/REC/STOP Key	
ETC DISP	Press the ▽ or △ key to display "IP" at the upper row.
↓▽ or △ Key	
IP OFF	Press the SET/REC/STOP key. "OFF" at the lower row starts blinking.
↓SET/REC/STOP Key	
IP OFF ↑Blinking	Press the ▽ or △ key to display "DISP".
↓▽ or △ Key	
IP DISP ↑Blinking	Press the SET/REC/STOP key to apply "DISP". Blinking stops.
↓SET/REC/STOP Key	
IP DISP	Proceed to the IP address setting procedure.

(3) Changing IP Address

The following shows the procedure to change the factory default "192.168.0.20" to "192.168.0.21".

Display (Upper/Lower)	Operation
IP DISP	Display the first segment of the IP address. Press the ∇ or Δ key until "P 1" appears at the upper row.
\downarrow ∇ or Δ Key	
IP 1 192	Check that "192" is displayed at the lower row, and press the ∇ key. If "192" is not displayed, change the value referring to the changing "IP 4" example shown later.
\downarrow ∇ Key	
IP 2 168	Check that "168" is displayed at the lower row, and press the ∇ key. If "168" is not displayed, change the value referring to the changing "IP 4" example shown later.
\downarrow ∇ Key	
IP 3 0	Check that "0" is displayed at the lower row, and press the ∇ key. If "0" is not displayed, change the value referring to the changing "IP 4" example shown later.
\downarrow ∇ Key	
IP 4 20	Press the SET/REC/STOP key to change the value displayed at the lower row to "21".
\downarrow SET/REC/STOP Key	
IP 4 020 \uparrow Blinking	The value starts blinking. Press the ∇ or Δ key to change the value to "21".
\downarrow ∇ or Δ Key	
IP 4 021 \uparrow Blinking	Press the SET/REC/STOP key to apply the value. Blinking stops.
\downarrow SET/REC/STOP Key	
IP 4 21	To check or change the subnet mask, press the ∇ key to display "SUB1" at the upper row.

\downarrow ∇ Key

Check that SUB1 to SUB4 are set to 255, 255, 255 and 0 respectively and apply them in the same way as the procedure above.

After the settings for IP 1 to IP 4 and SUB1 to SUB4 are completed, press the MODE key.

"RESET" is displayed and the unit resets itself after the MODE key is pressed again and THR mode is exited..

3.6.3 Setting the PC IP Address

This section describes the procedure to change the IP address of the PC to "192.168.0.100".

Login with a user account with administrator/manager authority, which is required to change the IP address of the PC.

(1) Windows XP

Follow the procedure below to set the IP address.

(1) Select "Start menu" – "Setup" – "Control Panel" to display the Control Panel and click "Network and Internet Connections".

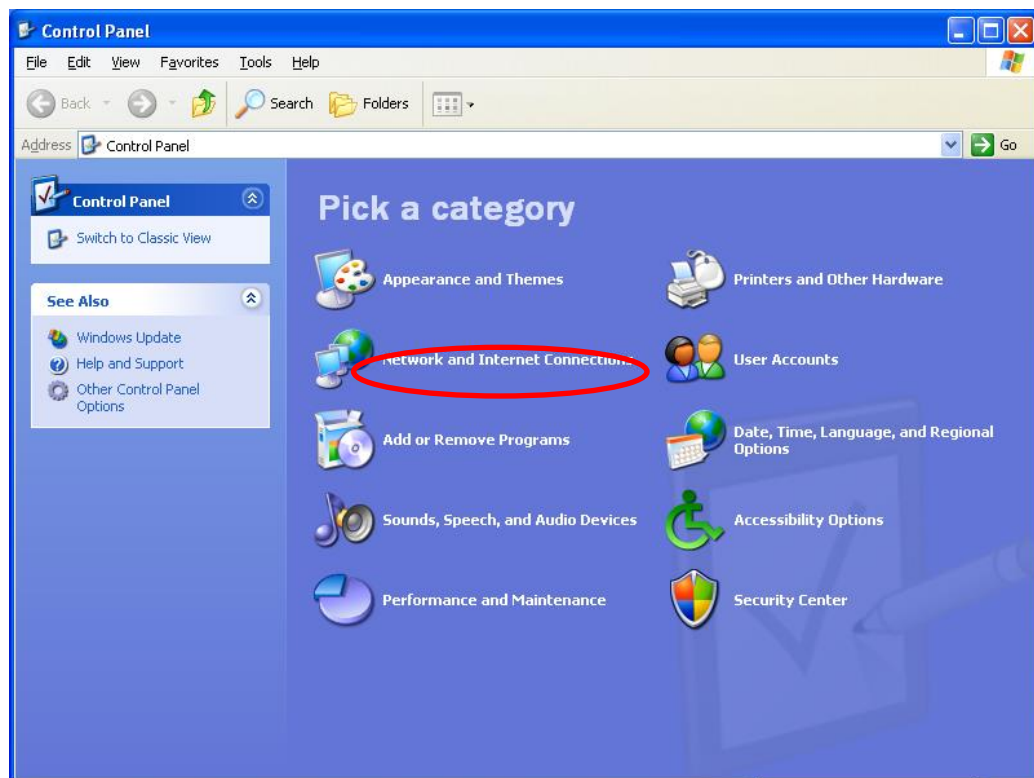

(2) Click "Network Connections".

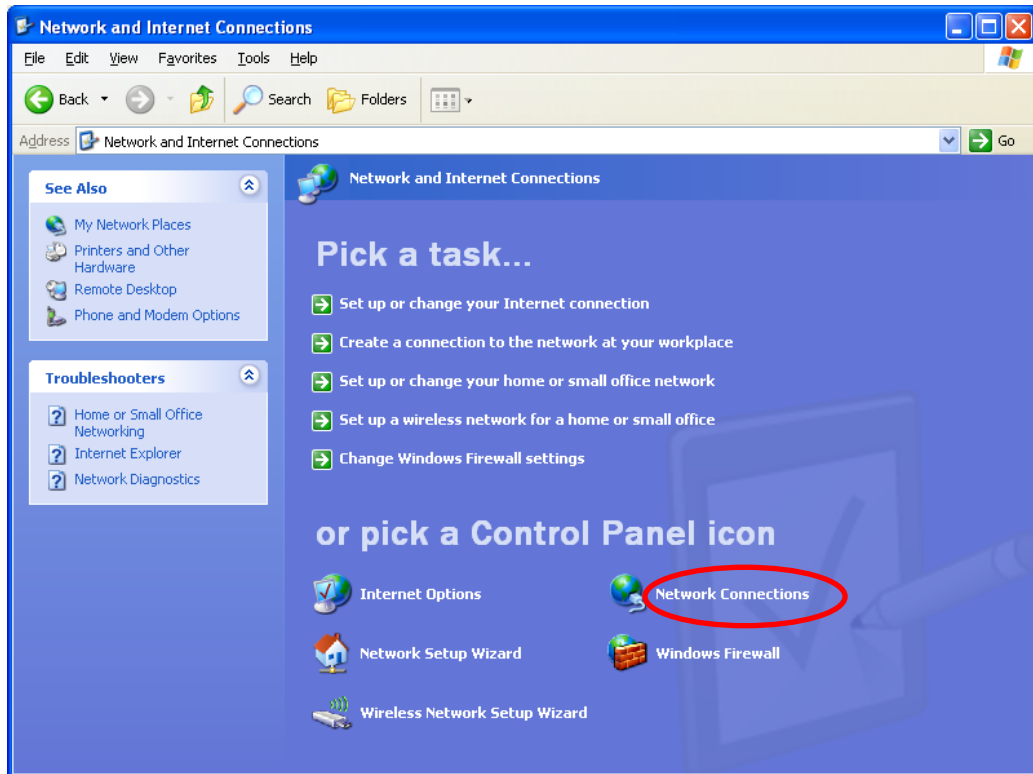

(3) Right-click "Local Area Connection" and select "Properties".

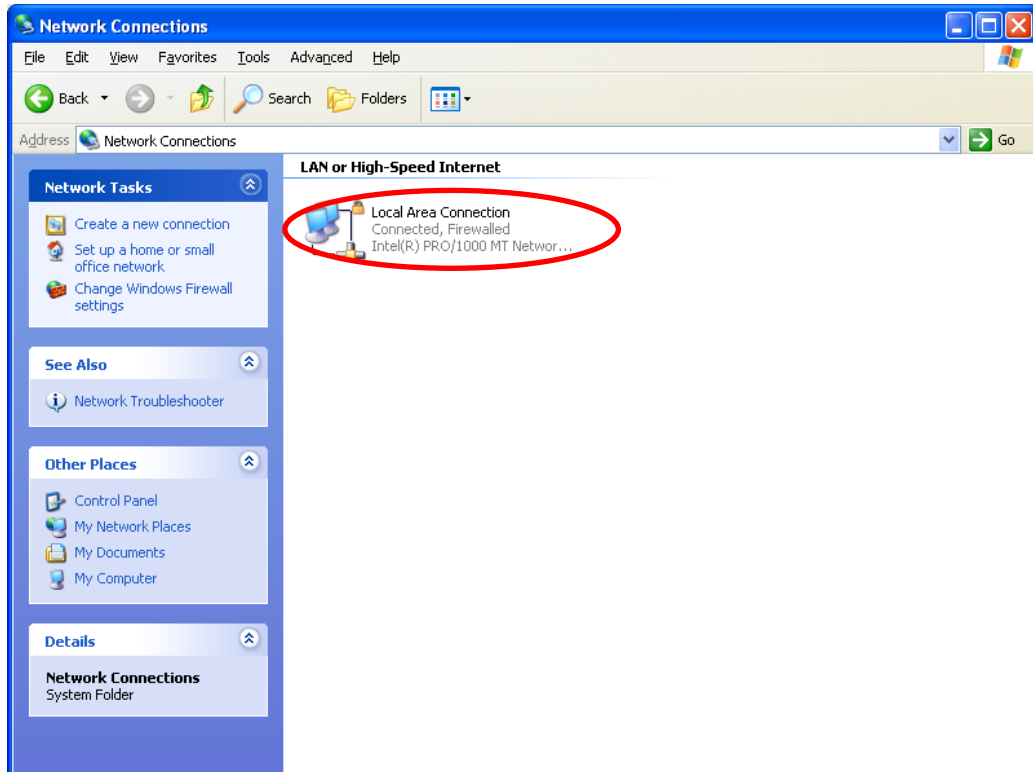

(4) Highlight "Internet Protocol (TCP/IP)" and click "Properties".

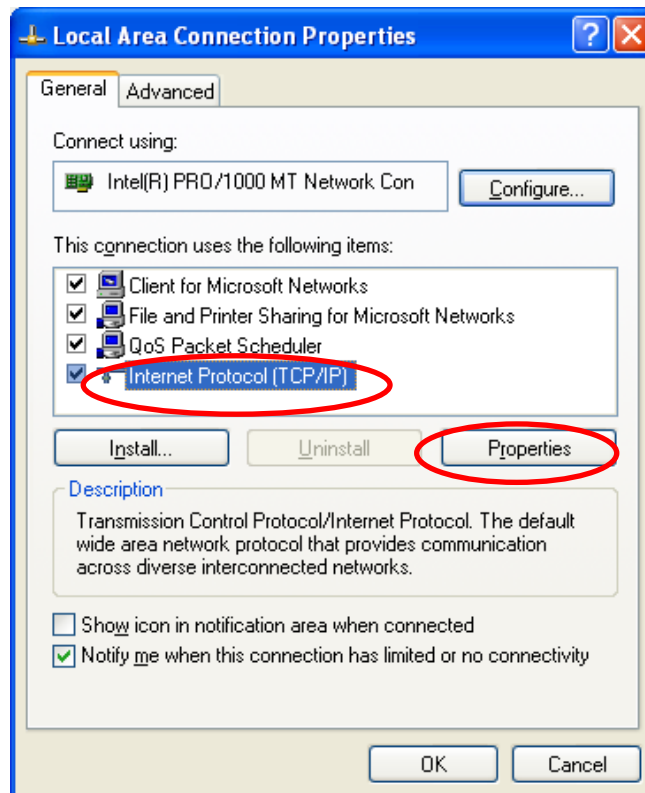

(5) Select "Use the following IP address" and set "IP address" to "192.168.0.100" and "Subnet mask" to "255.255.255.0". Press "OK" to close the window.

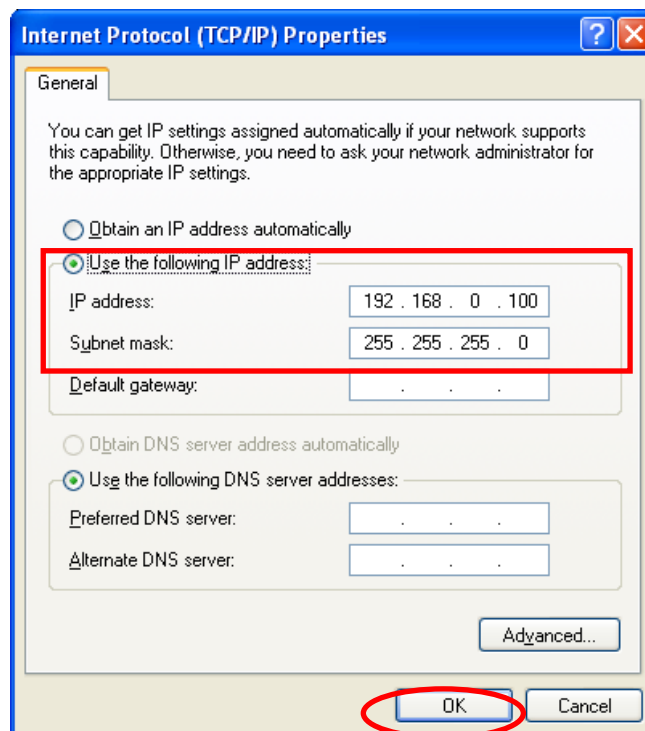

(6) Click "OK" in the "Local Area Connection Properties" window. The window closes.

(2) Windows Vista

Follow the procedure below to set the IP address.

(1) Select "Start menu" – "Control Panel" and click "Network and Internet".

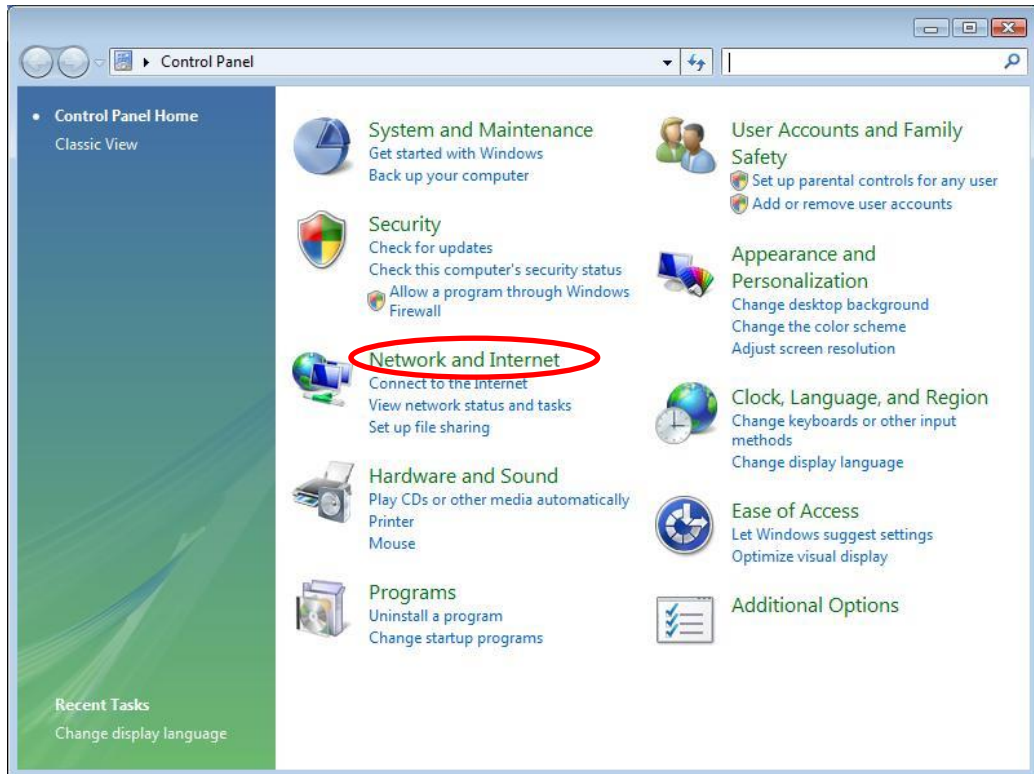

(2) Click "Network and Sharing Center".

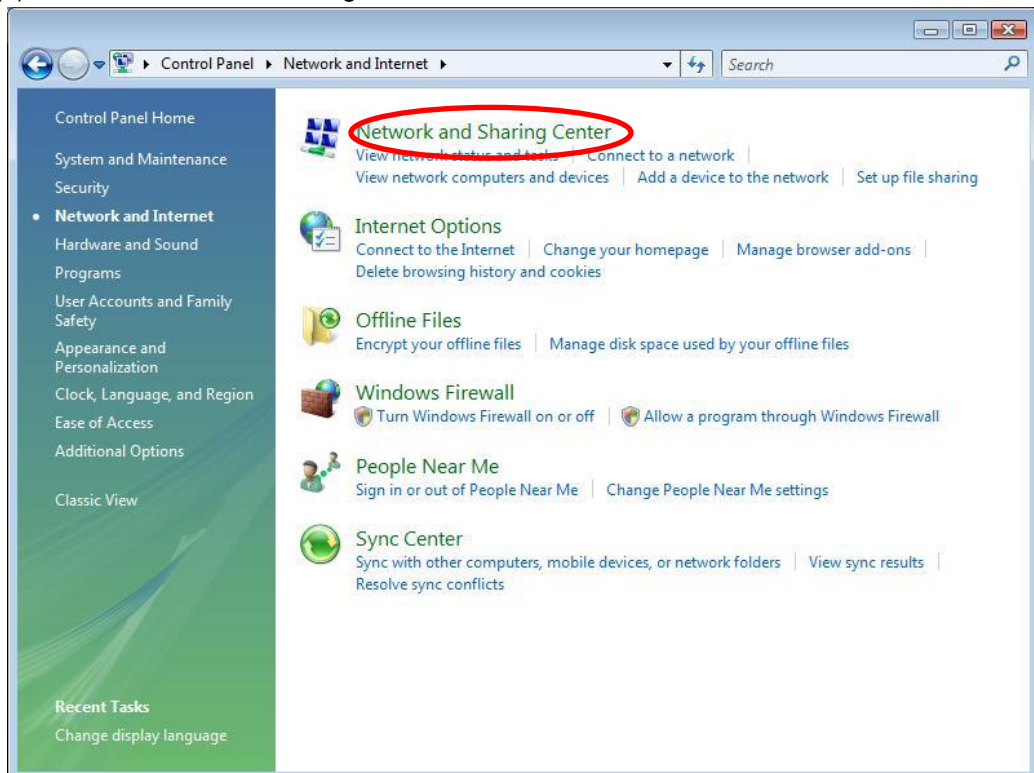

(3) Click "Manage network connections".

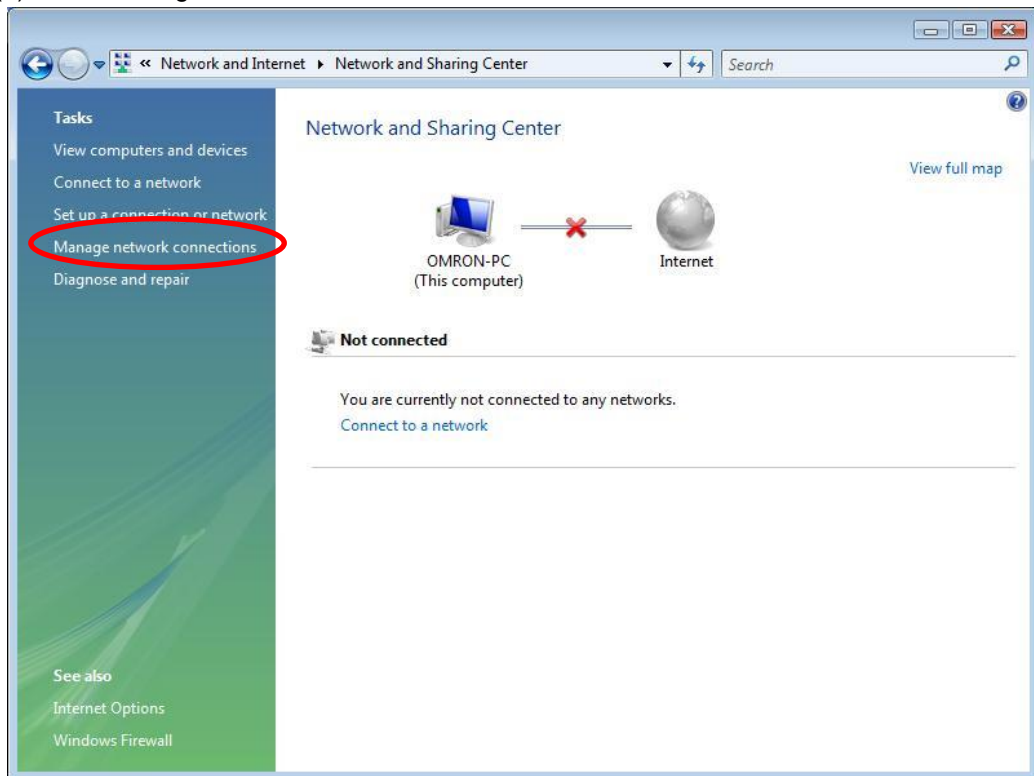

(4) Right-click "Local Area Connection" and select "Properties".

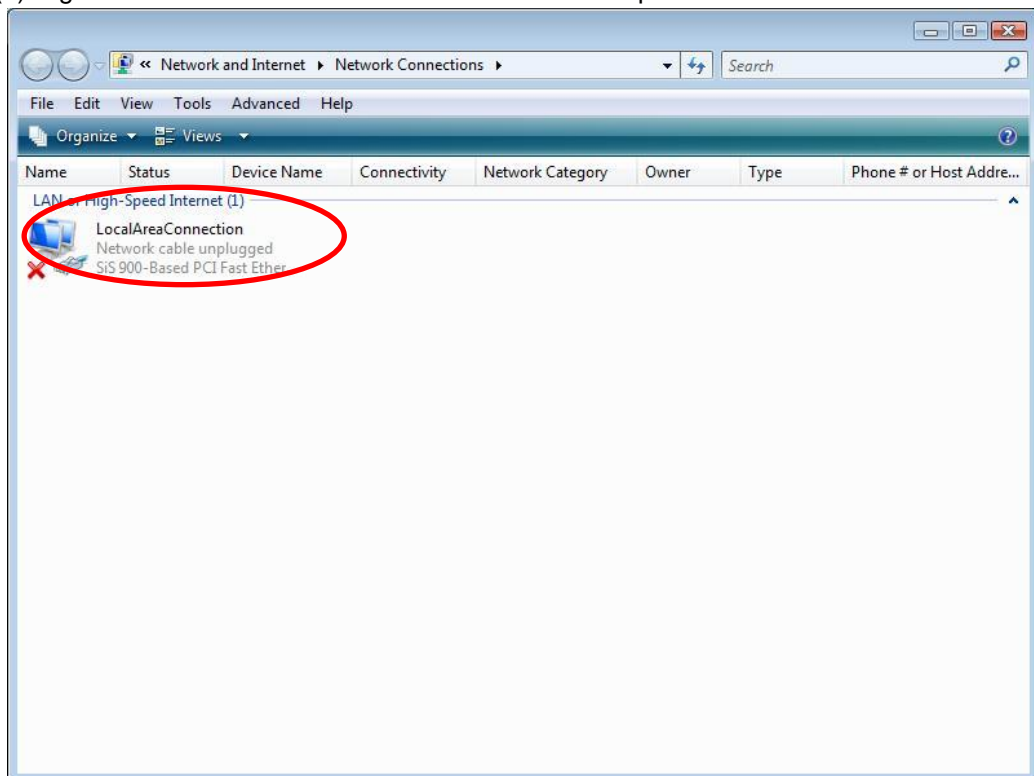

(5) When the "User Account Control" window appears, click "Continue".

(6) Select "Internet Protocol Version 4 (TCP/IPv4)" and click "Properties".

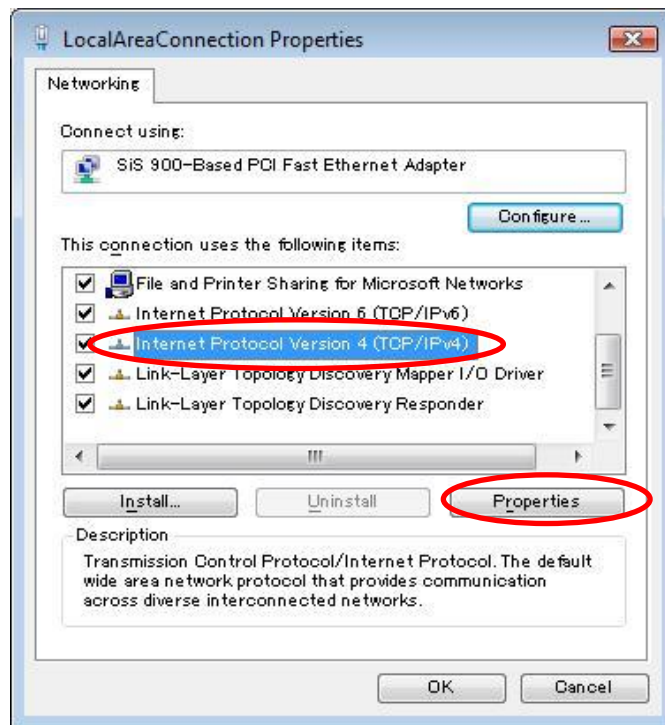

(7) Select "Use the following IP address" and set "IP address" and "Subnet mask". Click "OK" to close the window.

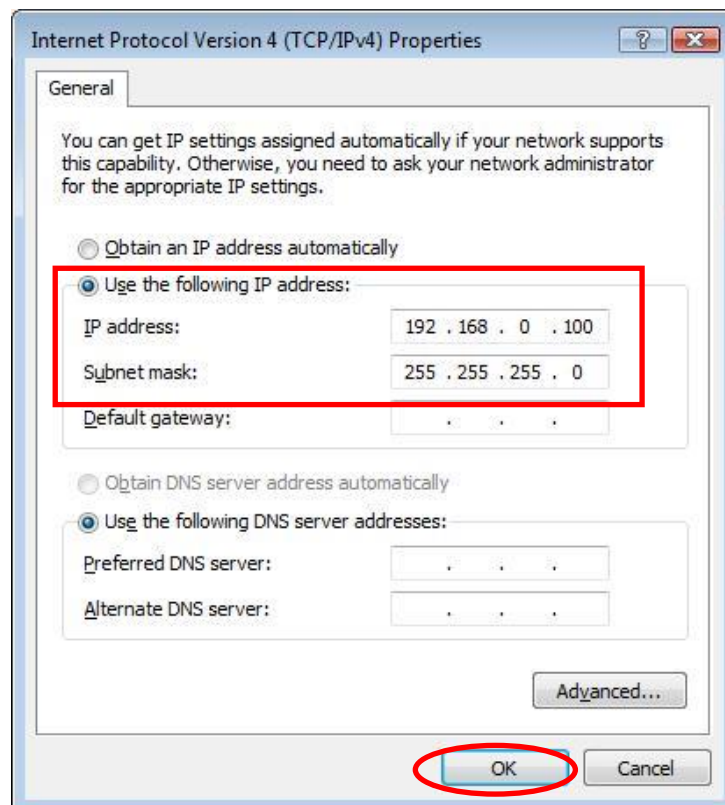

(8) Click "Close" in the "Local Area Connections Properties" window. The window closes.

(3) Windows 7

Follow the procedure below to set the IP address.

(1) Select "Start menu" – "Control Panel" and click "Network and Internet".

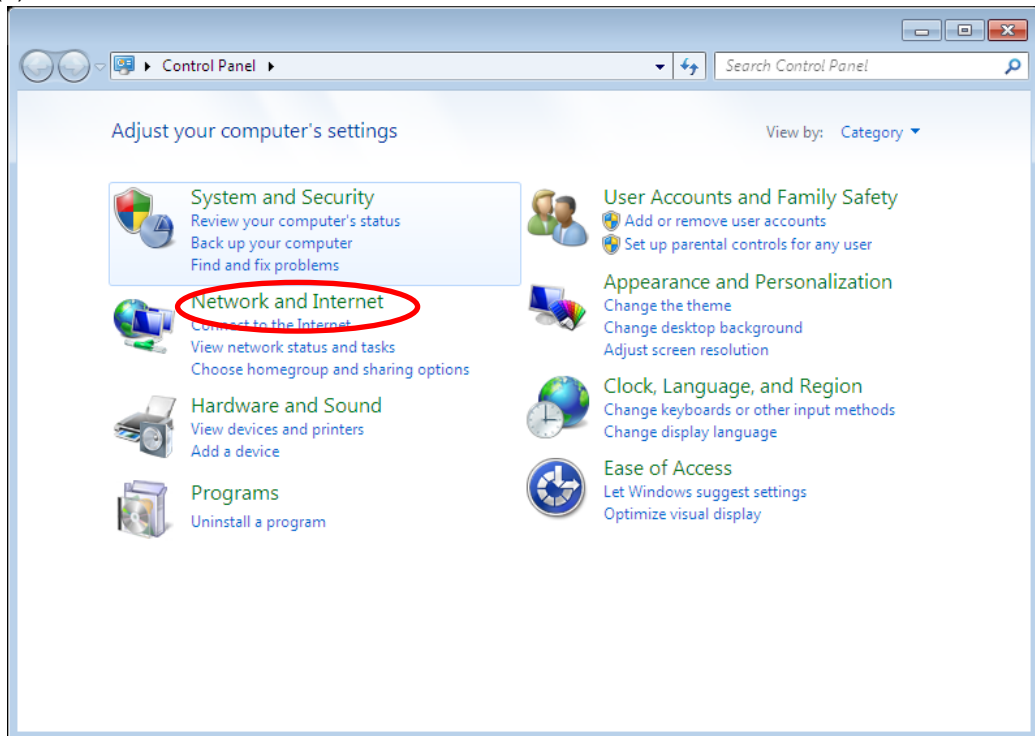

(2) Click "Network and Sharing Center".

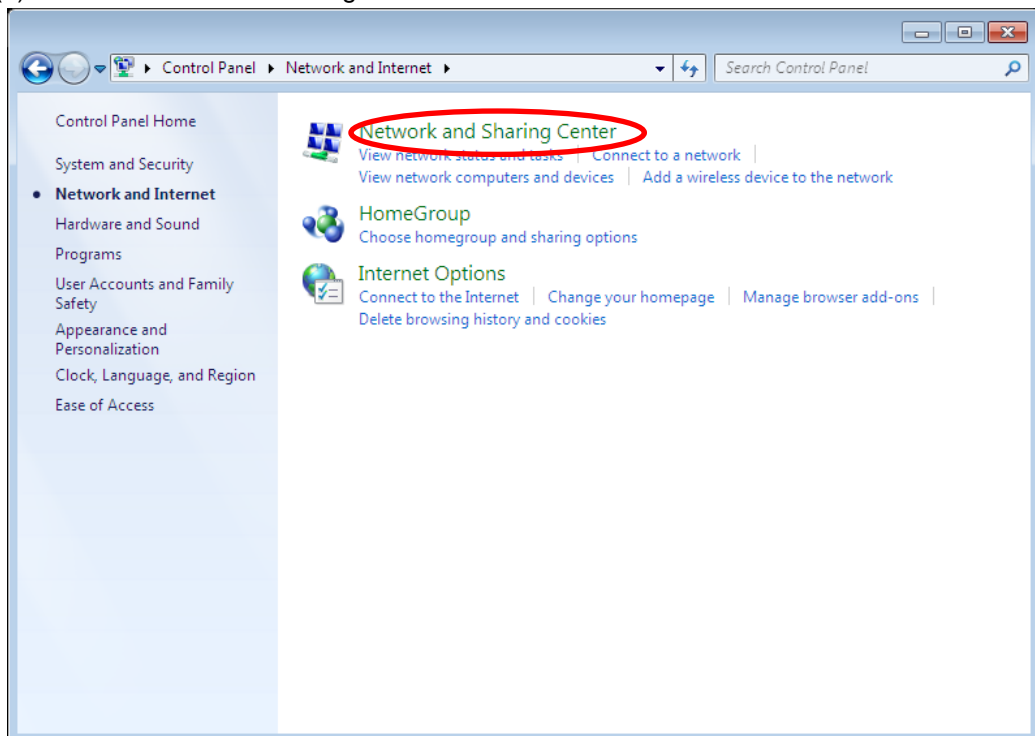

(3) Click "Change adapter settings".

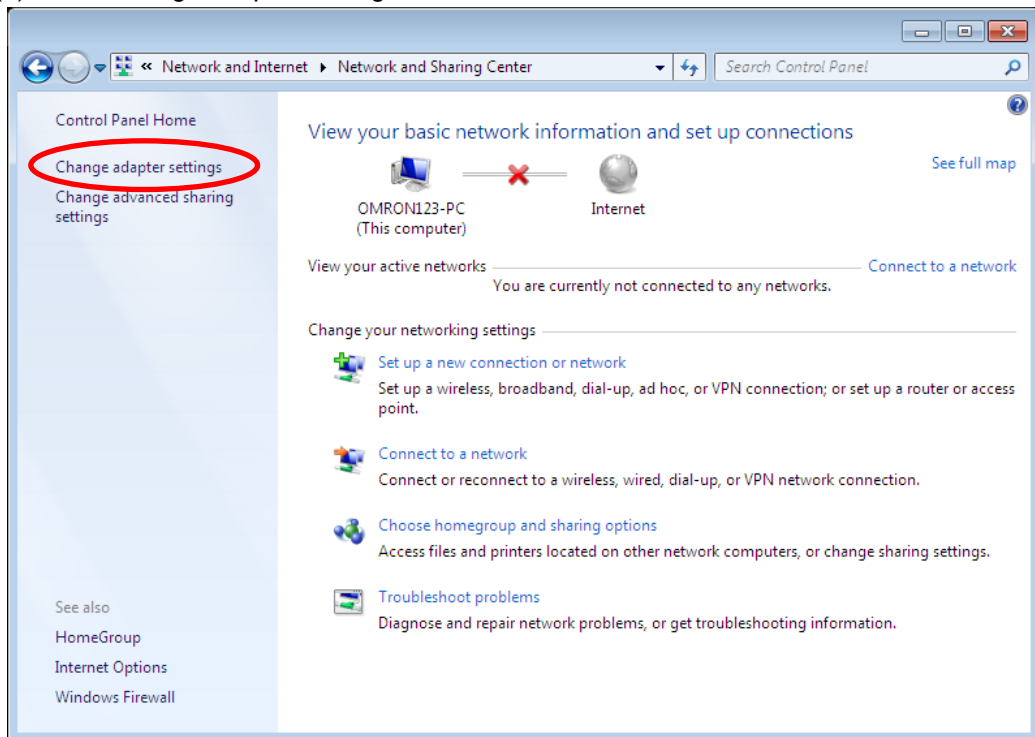

(4) Right-click "Local Area Connection" and select "Properties".

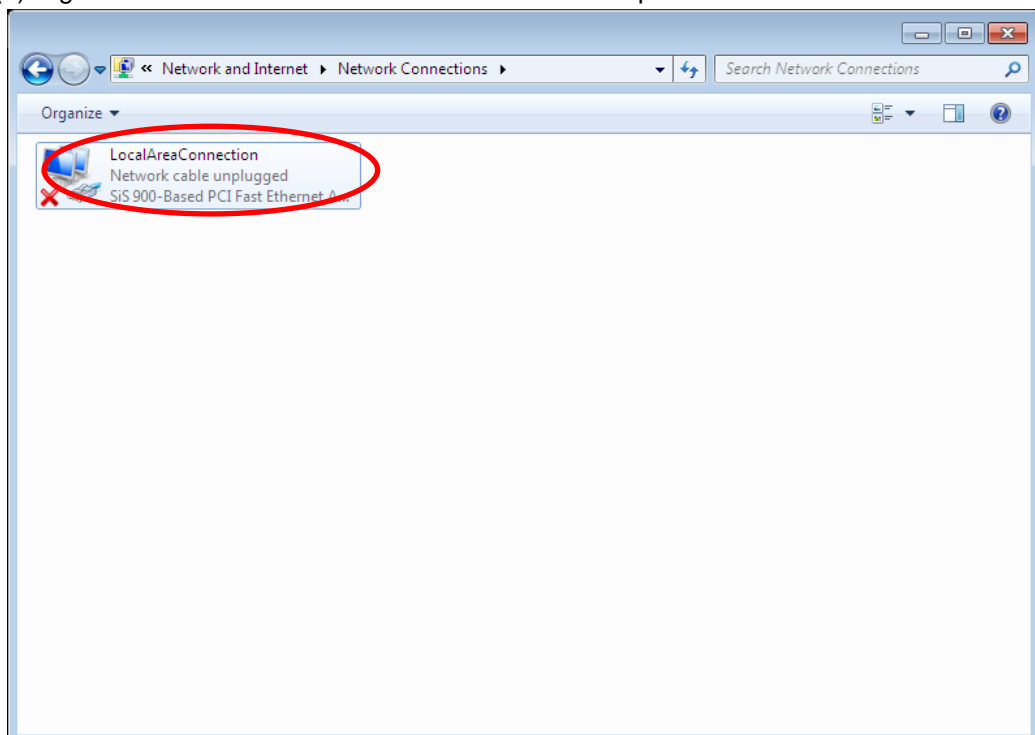

(5) Select "Internet Protocol Version 4 (TCP/IPv4)" and click "Properties".

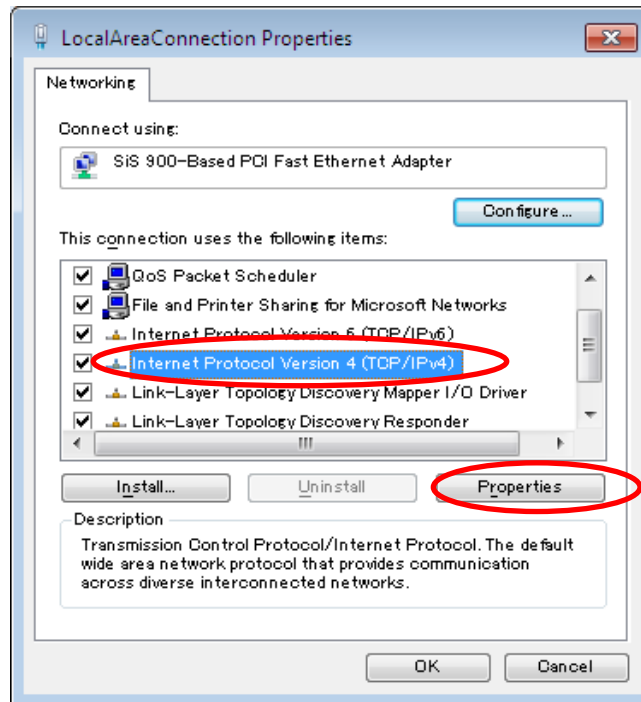

(6) Select "Use the following IP address" and set "IP address" and "Subnet mask". Click "OK" to close the window.

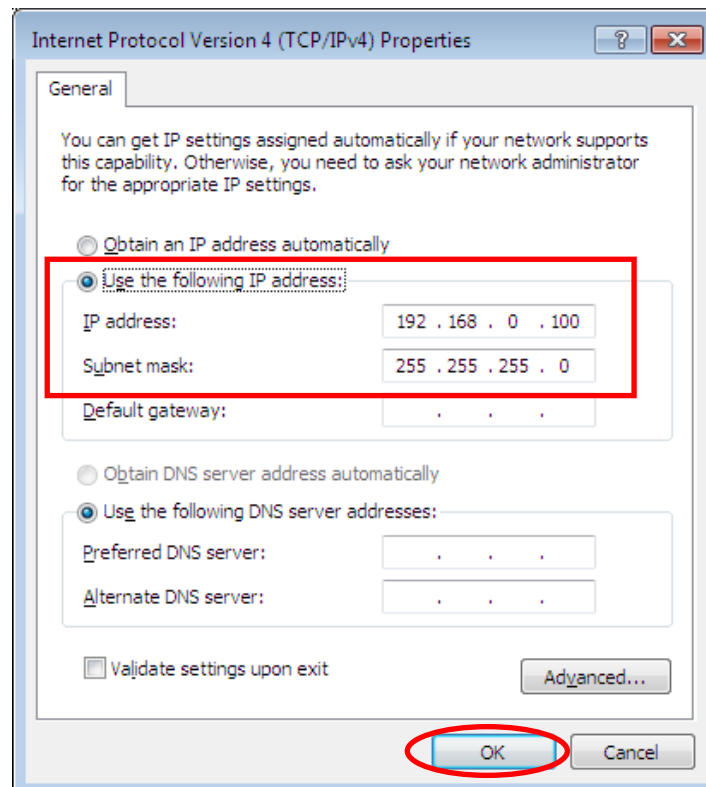

(7) Click "Close" in the "Local Area Connections Properties" window. The window closes.

3.6.4 Connecting a LAN Cable

Use a LAN cable to connect an Air Flow Station unit to the PC. The "LAN" symbol appears on the display when the unit is connected to the network.

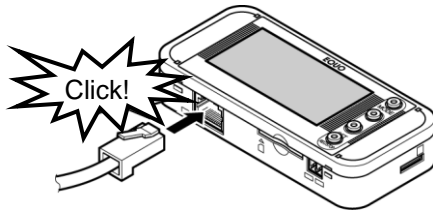

3.7 Mounting Air Flow Sensor and Air Flow Station

This section explains the procedure to mount Air Flow Sensor units to an Air Flow Station.

Important

This product is precision equipment. Be careful not to drop the unit.

3.7.1 Mounting Air Flow Sensor

(1) Mounting Air Flow Sensor to Supply Pipe

The following shows the supply pipe specifications for mounting an Air Flow Sensor.

Applicable Pipe Diameter: 25 A (Can be converted to 15 A, 20 A with a bushing)

Applicable Pipe: SUS Sch10S, SGP

The following two methods are available for mounting.

- Directly mount on the pipe
- Use a quick coupling

Be careful of the following points and install the Air Flow sensor. Secure piping with the tightening torque of 36 to 38 Nm.

- Do not apply excessive force on other than unit's screw or on the lead cable.
- Make sure that foreign objects do not enter inside the unit when piping.
- Be sure to check the flow direction before mounting pipes.

Note the following points to mount an Air Flow Sensor unit.

- Firmly tighten the screws at a torque from 36 to 38 N · m.
- Do not apply pressure to the main unit (except the screws) and the cable connector socket area.
- Make sure that foreign matter does not enter the unit when piping.
- Check the flow direction when mounting the unit.

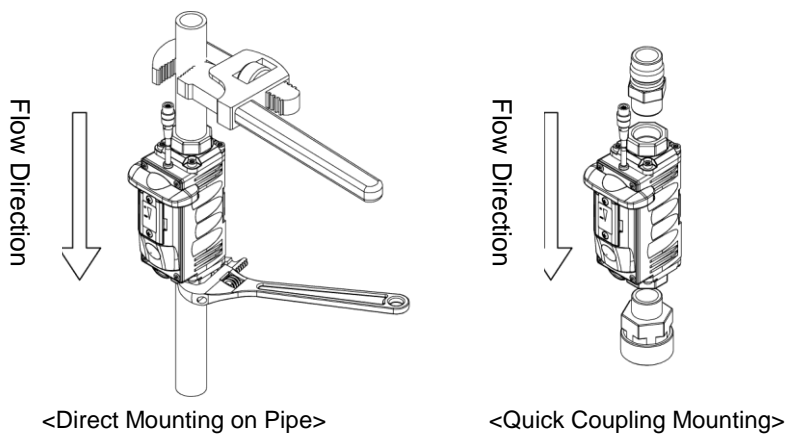

- Mounting on a vertical pipe is recommended to minimize the deposit of mist or dust inside the pipe.
- When mounting on a horizontal pipe, make sure that the status indicator does not face down. If this happens, mist or dust may deposit inside the pipe, causing malfunction.

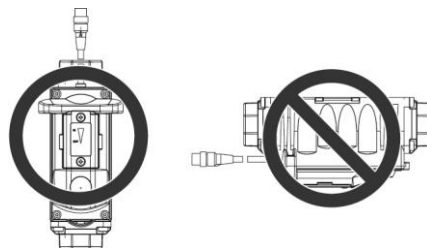

D6FZ-FGT□□□

The following shows the supply pipe specifications.

Applicable diameter: D6FZ-FGT200 / 8A(Rc1/4) D6FZ-FGT500 / 15A(Rc1/2)

Precautions for piping

When piping, fix with the part of conduit by wrench.

And secure piping with the tightening torque of the following list.

Model	Tightening torque
D6FZ-FGT200	12 to 14N.m
D6FZ-FGT500	31 to 33N.m

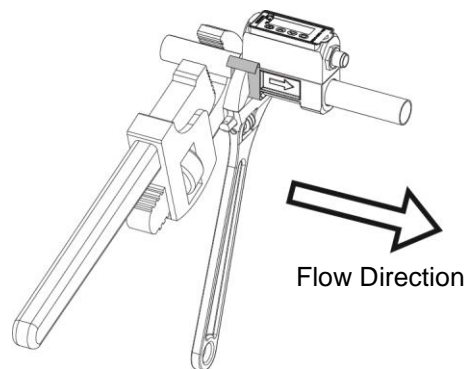

- Fix with only the conduit part when piping. Do not fix with other parts, or the product might be damaged.
- When fixing with the part of flow channel by wrench, cover the body with something like a waste cloth. If holding the body with a wrench directly, the body might be damaged.
- Check the flow direction before mounting pipes.
- Make sure that foreign objects do not enter inside the body when piping.
- Do not apply force on other than conduit.

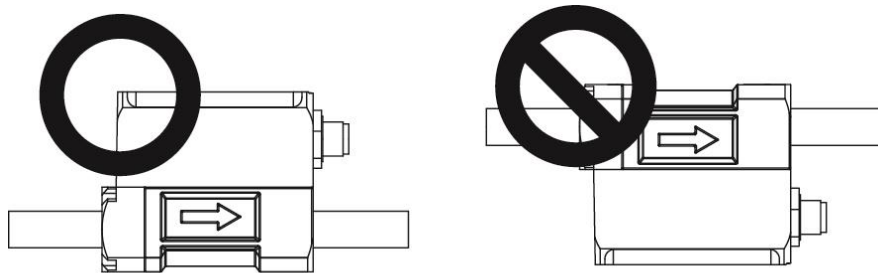

3.7.2 Mounting Air Flow Station Unit

Important

Use screws to fix the product through the provided mounting screw holes for installation on the wall or other equipment where vibration or shock may directly affect the unit.

(1) Free-stand Installation

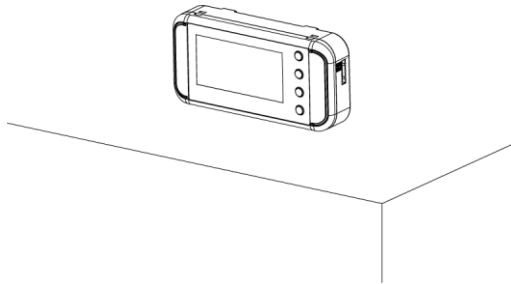
**Important**

When placing the product on a desk or other similar location, place it at a sufficient distance from the edges or corners of the object to prevent the unit from dropping to be damaged. Take caution in handling the connection cable and LAN cable to avoid their contacting the unit.

(2) Securing with Mounting Screws

Mounting screw holes are provided on the rear side of the unit, which enables fixing the unit on the wall or other vertical surface.

The holes also can hold round mounting magnets to magnetically secure the unit.

(Refer to the Appendix: Installation Diagram for the screw hole dimensions.)

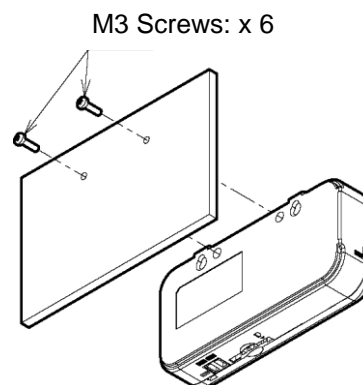
**Important**

The screw holes are 4 mm deep. Do not screw deeper than 4 mm, which may damage the product.

Note

- The unit can be magnetically secured by ZN9-WM01-S magnets (sold separately) placed in the screw holes. (Tightening torque: 0.4 N/cm to 0.6 N/cm)
- Mount the unit on a location where mechanical shock is not applied when mounting it with magnets.
- Be careful not to allow the sensor head and cable to apply pressure to the magnet-mounted unit.

Flat-head Screws: M3 x 6

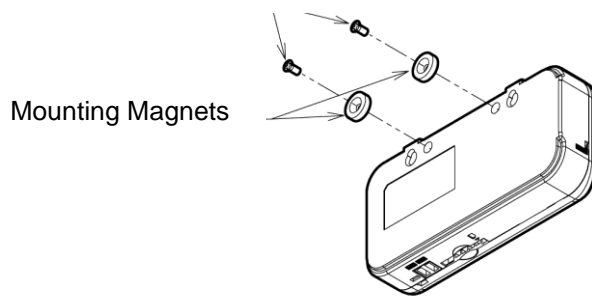
**(3) Mounting with Screw Hook Holes**

Two screw hook holes are provided below the convex section of the upper unit area, which allows fixing the unit on the wall or other vertical surface. (Refer to the Appendix: Installation Diagram for the screw hooking hole dimensions.)

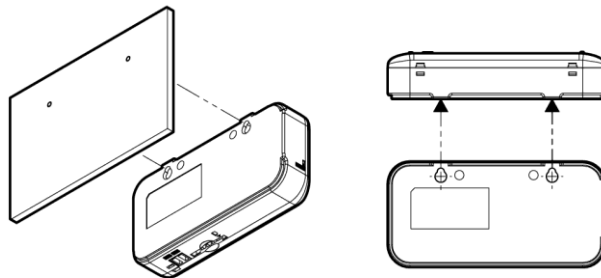

Fix M3 screws on the wall and hook the unit on the screw heads through the holes. Allow a distance of 2.5 mm or more between the bottom of the screw heads and the wall surface.

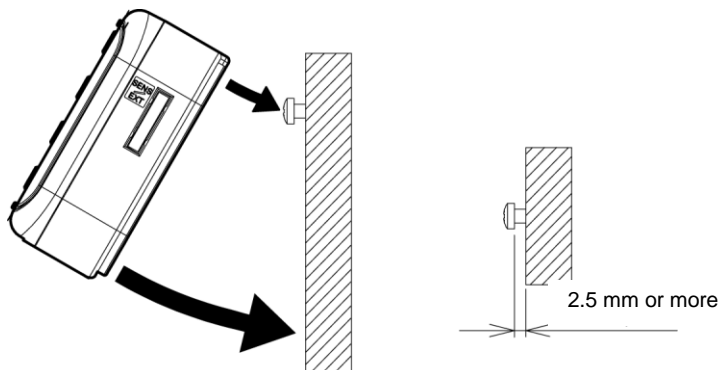

Enlarged Hook Screw Section View

Important

Firmly hold the unit with a hand to insert or remove the SD memory card if the unit is mounted by hooking. Otherwise the unit may drop on the floor and be damaged.

3.8 Remotely Setting Air Flow Sensors and Air Flow Station

Remote settings of Air Flow Sensor and Air Flow Station units from the PC via network are possible using the provided PC software.

Refer to the "User's Manual" of the provided PC software for the details of setting procedures.

4. Setting (Air Flow Station Operation)

Air Flow Sensor's settings can be changed by Air Flow Station.

But relating to the advanced settings of Air Flow Sensor D6FZ-FGT□□□, change a detailed setup by the key operation of a sensor.

Regarding to the operation, refer to the Instruction Sheet contained in the package.

4.1 Setting Procedure and Operation Modes

The following diagram shows the Air Flow Station setting procedure flow:

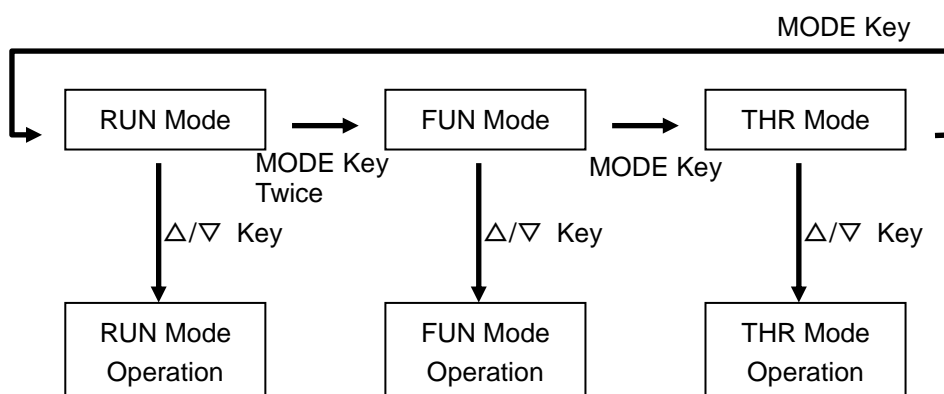

The Air Flow Station provides the three operation modes, which can be switched with the MODE key.

To change the mode from RUN to FUN, press the MODE key twice. When pressing the MODE key once, "RUN" blinks. When pressing it twice, "FUN" blinks and the mode is switched.

Use the Δ and ∇ keys to change and display items in each operation mode.

Display	Name	Description
"RUN" ON	Measurement Execution Mode (RUN Mode)	Used for air flow measurement and recording.
"FUN" Blinking	Function Setting Mode (FUN Mode)	Entered to make measurement and recording settings.
"THR" Blinking	Threshold Setting Mode (THR Mode)	Sets the threshold of the status indicator of Air Flow Sensor and the upper / lower limit thresholds of Air Flow Sensor for alarm outputs.

Note

- The mode cannot be changed during data recording in the internal memory in RUN mode ("REC" is displayed).
- During the transition from THR mode to RUN mode, the Air Flow Sensor process standby indication appears on the display.

4.2 Settings (FUN Mode Operation)

FUN mode provides the following settings:

- Air Flow Station measurement and recording settings
- Settings for Air Flow Sensor units (Pulse setting, Flow rate full-scale value*, Frequency of averaging, Measurement target gas*)

Note

The setting parameters for Air Flow Sensor units are retained in individual sensor units, and not in Air Flow Station units.

- * Settings of the flow rate full-scale value and Measurement target gas are available for only D6FZ-FGS1000.

4.2.1 List of Setting Items

The following list shows the setting items available in FUN mode.

Display Item		Display	Setting Item	Setting Value	Factory Default	
CYCLE		cycle	Data recording interval	1s (sec.)/2s/5s/10s/20s/30s/1m (min.)	1s	
UNIT		unit	Number of sensor units connected	1 to 8	1	
INIT		init	Initialize Air Flow Station settings	Initialization starts at a long press of the SET/REC/STOP key. The unit restarts when the MODE key is pressed twice and THR mode is exited after the "DONE" indication appears.	-	
(*1) NN.SET (DISP)	NN.PLS (*1)	nnPLS	Pulse setting	1.0/10.0/100.0/1000.0 (L/Pulse) (*2)	1.0	
	NN.SCL (*1)	nnSCL	Flow rate full-scale value	0 to 1000	1000	
	NN.AVE (*1)	nnAVE	Frequency of averaging	1/2/4/8/16/32 (times)	16 (*4)	
	NN.GAS (*1)	nnGAS	Measurement target gas	Air / N ₂	Air	
ETC (DISP)	RESTR		Read setting data from the SD memory card.	The unit reads setting data from a pre-inserted SD memory card at a long press of the SET/REC/STOP key and uses the data to set itself. The unit restarts when the MODE key is pressed twice and THR mode is exited after the "DONE" indication appears.	-	
	BCKUP		Write setting data to the SD memory card.	The unit saves the setting data in a pre-inserted SD memory card, at a long press of the SET/REC/STOP key.	-	
	CLOCK (DISP)	YEAR	year	Year	Year setting	Not initialized by INIT.
		MONTH	month	Month	Month setting	
		DAY	day	Day	Day setting	
TIME		time	Hour/Minute	Hour/minute setting		

IP (DISP)	IP1 to IP4	<i>IP</i>	IP address	0 to 255	192.168.0.20
	SUB1 to SUB4	<i>SUB</i>	Subnet mask	0 to 255	255.255.255.0
RATE		<i>RATE</i>	Rate/CO ₂ conversion value setting	0.000 to 99.999	0
CONV		<i>CONV</i>	Conversion unit	JPY/USD/EUR/CNY/KRW/CO2	JPY
FUNIT		<i>FUNIT</i>	Unit of display	L/min m ³ /min L/h m ³ /h	L/min
REREC		<i>REREC</i>	Auto backup and restarting record setting	ON/OFF	OFF

(*1) NN: Unit No. of the Air Flow Sensor which is designated by in RUN mode.

(*2): These values are for D6FZ-FGS1000.D6FZ-FGT□□□, setting values are 10.0/100.0/1000.0 (L/Pulse) . 1.0L/Pulse cannot be set.

(*3): These values are for D6FZ-FGS1000. D6FZ-FGT□□□, "----" is displayed (no selecting item)

(*4): This value is for D6FZ-FGS1000. For D6FZ-FGT□□□, default value is "8".

4.2.2 Selecting "FUN" Operation Mode

Press the MODE key to change the operation mode to "FUN". "FUN" at the lower right of the display starts blinking.

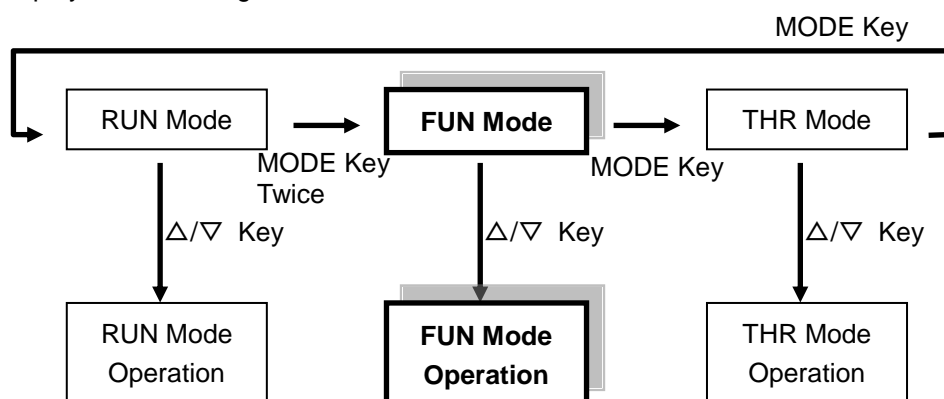

Note

FUN mode cannot be entered when recording in the internal memory is in progress in RUN mode ("REC" indicator is lighted on the display).

4.2.3 Selecting Items

Move the selection items using the Δ and ∇ keys. To change the set value, select the item with Δ or ∇ key and fix it with the SET/REC/STOP key. Press the MODE key to change the operation mode.

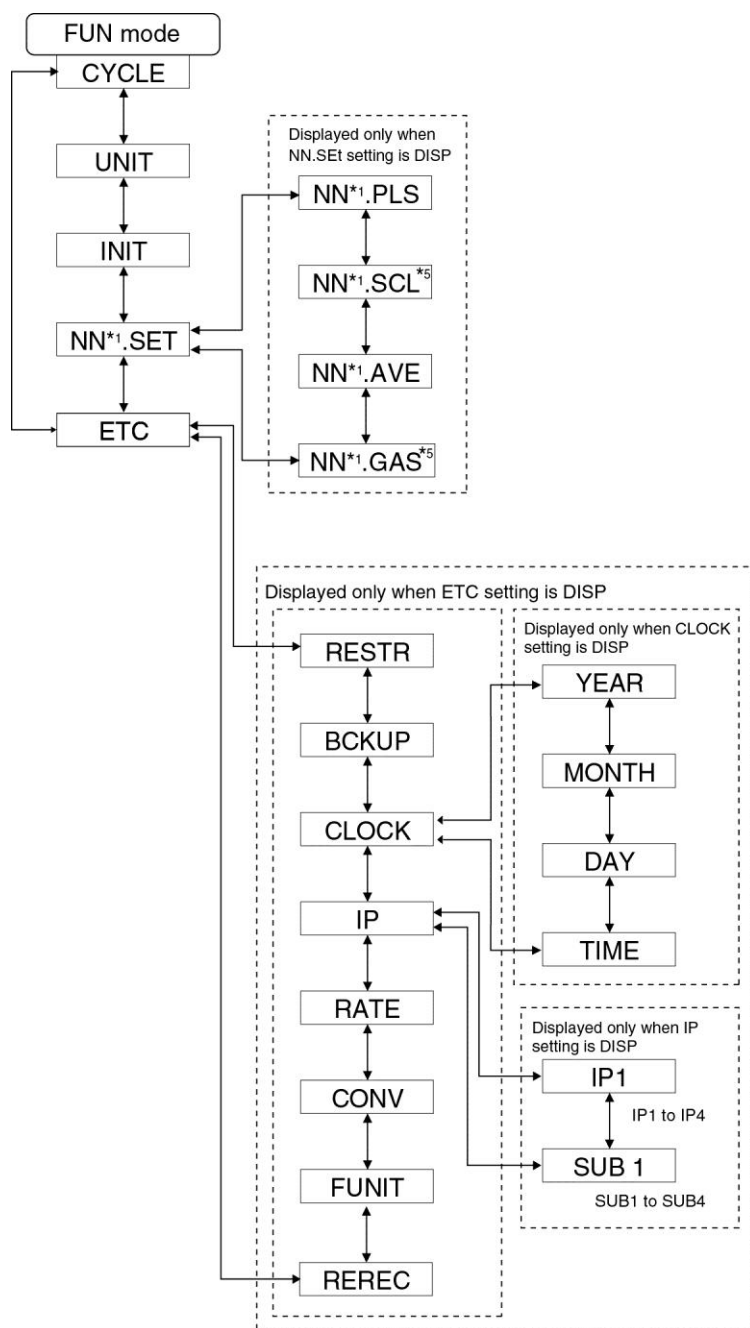

4.2.4 Description of Items

(1) Data Recording Interval (CYCLE)

Specifies the interval of measured value recording.

The range of selection (Options):

1s (second) / 2s / 5s / 10s / 20s / 30s / 1m (minute)

Initial value: 1s

(2) Number of Air Flow Sensor Units Connected (UNIT)

Specifies the number of Air Flow Sensor units to be connected.

The range of selection (Numeric input):

1 to 8

Initial value: 1

(3) Initialization (INIT)

The unit initializes the setting values and restores the factory defaults (except for year, month, day, hour and minute settings).

Important

The unit initializes setting values about Air Flow Station itself, not initializes the values about Air Flow Sensors. Please refer to the following table.

Initializes setting values	Not Initializes setting values
<ul style="list-style-type: none"> ▪ Data collection cycle ▪ Number of connected Air Flow Sensors ▪ IP address ▪ Rate conversion, CO2 conversion and the conversion unit. ▪ Auto backup and restarting record setting ▪ Alarm hold setting 	<ul style="list-style-type: none"> ▪ Year, Month, Day, Hour, Minute, Second ▪ Sensor setting values (Pulse setting, Flow full-scale value, Averaging count, Measurement target gas) ▪ Sensor threshold value (Hi, Lo, Cut)

Operation:

Holding the SET/REC/STOP key starts initialization and it is finished when "DONE" is displayed. Before showed "DONE", the initialization is canceled.

After initialization, press the MODE key twice to exit THR mode. The unit is restarted and the setting values are initialized.

(4) Setting for Air Flow Sensor (NN.SET)

Specifies whether the items including Air Flow Sensor pulse setting, Flow rate full-scale value, Frequency of averaging, and Measurement target gas are displayed or not. The setting is made for the Air Flow Sensor unit whose ID is selected in RUN mode.

NN : Unit No. of the Air Flow Sensor which is designated by in RUN mode.

The range of selection (Options):

OFF / DISP

Initial value:

OFF

Setting Value	Operation
OFF	The unit does not display the items including Pulse setting, Flow rate full-scale value, Frequency of averaging, and Measurement target gas. The ETC item returns when the ∇ key is pressed after the setting is applied with the SET/REC/STOP key.
DISP	The unit displays the items including Pulse setting, Flow rate full-scale value, Frequency of averaging, and Measurement target gas. The NN.SET item is displayed when the ∇ key is pressed after the setting is applied with the SET/REC/STOP key.

Note

The NN.SET setting returns to "OFF" when the unit is reset.

(5) Pulse Setting

Specifies the integrated flow rate for a single pulse output from the Air Flow Sensor unit. The pulse toggles ON/OFF when the sensor detects the half of a specified flow rate.

D6FZ-FGS1000

The range of selection (Options):

1.0/10.0/100.0/1000.0 (L/Pulse)

Initial value:

10.0

D6FZ-FGT□□□

The range of selection (Options):

10.0/100.0/1000.0 (L/Pulse)

Initial value:

10.0 (D6FZ-FGT200/500)

Note

The Pulse setting is not available when NN.SET is set to OFF.

The momentary flow units of the Air Flow Station are m^3/min or m^3/h , the unit of pulse is m^3/Pulse .

(E.g. 1.0 L/Pulse \rightarrow 0.001 m^3/Pulse , 1000.0 L/Pulse \rightarrow 1.0 m^3/Pulse)

(6) Flow Rate Full-Scale Value

Specifies the flow rate full-scale value for Analog Output 1 from the Air Flow Sensor unit.

D6FZ-FGS1000

The range of selection (Numeric input):

0 to 1000

Initial value:

1000

D6FZ-FGT□□□

The range of selection (Options):

Initial value:

(none)

Note

The Flow rate full-scale value setting is not available when NN.SET is set to OFF.

(7) Frequency of Averaging

Specified the frequency of averaging when obtaining the measured value.

The range of selection (Options):

1/2/4/8/16/32 (times)

Initial value:

16

Note

The Frequency of averaging setting is not available when NN.SET is set to OFF.

* For D6FZ-FGT□□□, default value is "8".

(8) Measurement Target Gas

Specifies the gas to be measured by the Air Flow Sensor unit.

D6FZ-FGS1000

The range of selection (Options):

AIR / N₂

Initial value:

AIR

D6FZ-FGT□□□

The range of selection (Options):

Initial value:

(none)

Setting Value	Description
AIR	Air
N ₂	Nitrogen

Note

The Measurement target gas setting is not available when NN.SET is set to OFF.

(9) Others (ETC)

Specifies if the unit displays the items for setting file read/write, time setting, IP address, rate/CO₂ conversion value setting and conversion unit setting.

The range of selection (Options):

OFF / DISP

Initial value: OFF

Setting Value	Operation
OFF	The unit does not display the items for setting file read/write, time setting, IP address, rate/CO ₂ conversion value setting and conversion unit setting. The CYCLE item returns when the ∇ key is pressed after the setting is applied with the SET/REC/STOP key.
DISP	The unit displays the items for setting file read/write, time setting, IP address, rate/CO ₂ conversion value setting and conversion unit setting. The RESTR item is displayed when the ∇ key is pressed after the setting is applied with the SET/REC/STOP key.

Note

The ETC setting returns to "OFF" when the unit is reset.

(10) Reading Setting Data (RESTR)

Restores the Air Flow Station unit settings by using the SD memory card with the setting data saved as a backup using the BCKUP setting (described later).

Operation:

Insert the SD memory card containing the setting data, and hold the SET/REC/STOP key. Reading is completed when "DONE" is displayed.

The process standby display appears and initialization starts after the process is complete. If the key is released before the process is complete, initialization is cancelled.

The unit resets itself when the MODE key is pressed twice and THR mode is exited after initialization is complete.

Note

- Only one setting data item (the setting data for only one Air Flow Station unit) can be stored in a single SD memory card as a backup.
- Setting data reading is not possible when ETC is set to "OFF".
- Air Flow Sensor settings are not backed up.

(11) Writing the Setting Data (BCKUP)

Saves the Air Flow Station unit setting data in an SD memory card as a backup.

Operation:

Insert an SD memory card and hold the SET/REC/STOP key.

Saving is complete when "DONE" is displayed.

The process standby display appears and initialization starts after the process is complete. If the key is released before the process is complete, initialization is cancelled.

Important

Only one setting data item (the setting data for only one unit) can be stored in a single SD memory card as a backup. If an SD memory card containing an already-saved setting data backup is used, the setting data in the card is overwritten. The same applies to a backup performed on other Air Flow Station units: the data is overwritten.

Note

- The setting data is written into the SYSTEM folder in the SD memory card.
- Setting data writing is not possible when ETC is set to "OFF".
- Air Flow Sensor settings are not backed up.

(12) Setting Clock (CLOCK)

Specifies if the internal clock setting is required.

The range of selection (Options):

OFF / DISP

Initial value: OFF

Setting Value	Operation
OFF	Time setting is not available. The IP item is displayed when the ▽ key is pressed after the setting is applied with the SET/REC/STOP key.
DISP	Time setting is available. The YEAR item is displayed when the ▽ key is pressed after the setting is applied with the SET/REC/STOP key.

Note

- The CLOCK setting is not possible when ETC is set to "OFF".
- The CLOCK setting returns to "OFF" when the unit is reset.

(13) YEAR/MONTH/DAY/TIME Setting

Specifies the year/month/day/time values.

The range of selection (Numeric input):

YEAR: 2000 to 2099

MONTH: 1 to 12

DAY: 1 to 31

TIME: 00:00 to 23:59

Note

The year/month/day/time settings are not possible when ETC is set to "OFF" and CLOCK is also set to "OFF".

(14) Setting IP Address (IP)

Specifies if the IP address setting is required.

The range of selection (Options):

OFF / DISP

Initial value: OFF

Setting Value	Operation
OFF	IP address setting is not available. The SDISP item is displayed when the ∇ key is pressed after the setting is applied with the SET/REC/STOP key.
DISP	IP address setting is available. The IP 1 item is displayed when the ∇ key is pressed after the setting is applied with the SET/REC/STOP key.

Note

- The IP setting is not possible when ETC is set to "OFF".
- The IP setting returns to "OFF" when the unit is reset.

(15) IP Address and Subnet Mask (IP 1 to IP 4, SUB 1 to SUB 4)

Specifies the 4 segments of the IP address (IP 1 to IP 4) and the 4 segments of the subnet mask (SUB 1 to SUB 4).

The range of selection (Numeric input):

IP 1, IP 2, IP 3, IP 4: 0 to 255

SUB 1, SUB 2, SUB 3, SUB 4: 0 to 255

Initial value: IP 1.IP 2.IP 3.IP 4 = 192.168.0.20

SUB 1.SUB 2.SUB 3.SUB 4 = 255.255.255.0

Note

- The unit resets itself when the MODE key is pressed twice and THR mode is exited, after the IP address and subnet mask values have been changed and applied with the SET/REC/STOP key.
- The IP address and subnet mask settings are not possible when ETC is set to "OFF" and IP is also set to "OFF".

(16) Rate/CO₂ Conversion Value Setting (RATE)

Specifies the rate or CO₂ emission level per 1 m³ of integrated flow rate.

The range of selection (Numeric input):

0.000 to 99.999 (times)

Initial value: 0

Note

The rate/CO₂ conversion value setting is not possible when ETC is set to "OFF".

(17) Conversion Unit Setting (CONV)

Specifies the unit for the rate/CO₂ conversion setting (RATE).

The range of selection (Options):

JPY (Japanese yen) / USD (US dollar) / EUR (Euro) / CNY (Chinese yuan) / KRW
(Korean won) / CO₂ (CO₂ emission level per 1m³)

Initial value: JPY

Note

The conversion unit setting is not possible when ETC is set to "OFF".

(18) Unit of Display Setting (FUNIT)

Specifies the unit for displaying the momentary standard flow rate.

The range of selection (Options):

L/min, m³/min, L/h m³/h

Initial value: L/min

Note

The unit of display cannot be specified when ETC is set to "OFF".

(19) Auto backup and restarting record setting (REREC)

When this function is ON, if power shutdown happens during the record, the recorded measurement data before the interruption of power is backed up to SD memory card and record is resumed after power is back.

While this function is ON, insert the recordable SD memory card into the SD memory card slot.

After restarting record, integrated flow value is not cleared.

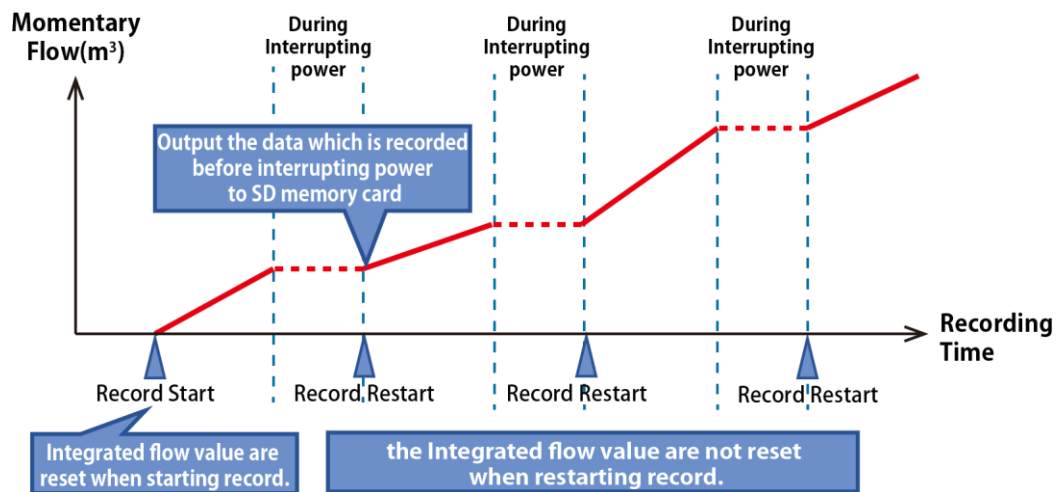

4.2.5 Changing Air Flow Station Set Value

This section explains the procedure to change Air Flow Station set values.

The value setting depends on the type of items, which are classified into option selection type and numeric input type.

(1) Changing Option Type Item Value (Example: CYCLE)

Press the MODE key several times to enter FUN mode, and press the ∇ or Δ key to display CYCLE.

Display (Upper/Lower)	Operation
CYCLE 1s	Press the MODE key repeatedly until "FUN" starts blinking. Press the ∇ or Δ key to display CYCLE at the upper row of the display. Press the SET/REC/STOP key, then, the value at the lower row starts blinking.

↓SET/REC/STOP Key

Display (Upper/Lower)	Operation
CYCLE 1s ↑Blinking	The value options are displayed in sequence by pressing the Δ or ∇ key. To cancel the setting attempt, press the MODE key.

↓ ∇ or Δ Key

Display (Upper/Lower)	Operation
CYCLE 30s ↑Blinking	Press the Δ or ∇ key to display the desired value, and press the SET/REC/STOP key.

↓SET/REC/STOP Key

Display (Upper/Lower)	Operation
CYCLE 30s	The setting is complete when the value stops blinking.

Use the Δ or ∇ key again to display another setting item and MODE key to change the operation mode.

(2) Changing Numeric Input Type Item Value (Example: YEAR)

Press the MODE key several times to enter FUN mode, and press the ∇ or Δ key to display YEAR.

To display YEAR, ETC and CLOCK must have been set to DISP beforehand.

Display (Upper/Lower)	Operation
CYCLE 1s ("FUN" Blinking)	Press the MODE key repeatedly until "FUN" starts blinking. "CYCLE" is displayed at the upper row. Press the ∇ or Δ key to display YEAR. To display YEAR, ETC and CLOCK must be set to DISP.

↓ ∇ or Δ Key

Display (Upper/Lower)	Operation
YEAR 2010	Press the SET/REC/STOP key, then, the last digit number at the lower row starts blinking.

↓SET/REC/STOP Key

Display (Upper/Lower)	Operation
YEAR 2010 ↑Blinking	The value increases or decreases at a press of the Δ or ∇ key. The amount of increase/decrease becomes larger by holding Δ or ∇ key. To cancel the setting attempt, press the MODE key.

↓ ∇ or Δ Key

Display (Upper/Lower)	Operation
YEAR 2011 ↑Blinking	Press the Δ or ∇ key to display the desired value, and press the SET/REC/STOP key.

↓SET/REC/STOP Key

Display (Upper/Lower)	Operation
YEAR 2011	The setting is complete when the value stops blinking.

Use the Δ or ∇ key again to display another setting item and MODE key to change the operation mode.

4.2.6 Changing Air Flow Sensor Set Value

This section explains the procedure to change Air Flow Sensor set values.
Follow the steps below.

- (1) Display the ID of the target Air Flow Sensor unit in RUN mode.

(Refer to "5.3 Screen Transition in RUN Mode" for details of the operation procedure.)

Display (Upper/Lower)	Operation
01.F01 Integrated Standard Flow Rate ("RUN" Blinking)	Press the MODE key repeatedly until "RUN" starts blinking. The Air Flow Sensor unit ID and measured value code is displayed at the upper row. The measured value is displayed at the lower row. The integrated standard flow rate is displayed here. A long press of the Δ key switches Air Flow Sensor unit IDs. Hold the key until the ID of the target unit appears.

↓ Hold Δ Key

Display (Upper/Lower)	Operation
03.F01 Integrated Standard Flow Rate	For example, display "03" as the ID.

- (2) Switch the mode to FUN mode and set NN.SET to "DISP".

Display (Upper/Lower)	Operation
CYCLE 1s ("FUN" Blinking)	Press the MODE key repeatedly until "FUN" starts blinking. (The status indicator of the ID03 Air Flow Sensor blinks in yellow when the unit enters FUN mode.) "CYCLE" is displayed at the upper row. Press the ∇ or Δ key to display NN.SET.

↓ ∇ or Δ Key

Display (Upper/Lower)	Operation
NN.SET OFF	Press the SET/REC/STOP key. The set value at the lower row starts blinking.

↓ SET/REC/STOP Key

Display (Upper/Lower)	Operation
NN.SET OFF ↑Blinking	Press the ∇ or Δ key to display DISP, and then, press the SET/REC/STOP key.

↓ SET/REC/STOP Key

Display (Upper/Lower)	Operation
NN.SET DISP ↑Blinking	The setting is applied when DISP stops blinking.

(3) Change the setting item value for the Air Flow Sensor unit.

The values for the Pulse setting (NN.PLS), Flow rate full-scale (NN.SCL), Frequency of averaging (NN.AVE) and Measurement target gas (NN.GAS) items can be changed in the same way.

(Refer to "4.2.5 Changing Air Flow Station Set Value" for the operation procedure.)

* Flow full-scale value and measurement target gas can be set by only D6FZ-FGS1000.

On D6FZ-FGT□□□, the "-----" is displayed and the setting is not available.

(4) To change set values for Air Flow Sensor unit, display the target sensor's ID in RUN mode and repeat steps 1 to 3.

During changing setting values by Air Flow Station, the indicator of the D6FZ-FGS1000 is blinking with yellow light, and D6FZ-FGT□□□ displays "REMOTE" and key operations are not available.

When mode of the Air Flow Station is returned to RUN-mode, the sensors will return to normal operation.

4.3 Settings (THR Mode Operation)

THR mode provides the following settings:

- Air Flow Sensor thresholds
- Air Flow Station alarm hold setting

Note

The setting parameters for Air Flow Sensor units are retained in individual sensor units, and not in Air Flow Station units.

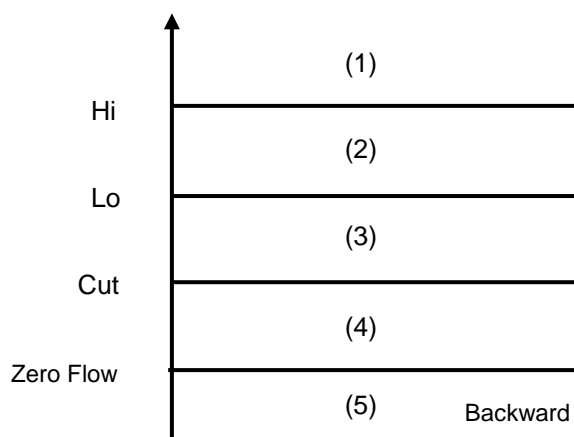

The Air Flow Sensor thresholds are set to the following values by factory default:

Model	D6FZ-FGS1000	D6FZ-FGT500	D6FZ-FGT200
Hi (Upper threshold)	1000 L/min	250 L/min	100 L/min
Lo (Lower threshold)	0 L/min	250 L/min	100 L/min
Cut (Leak Detection Flow Rate)	0 L/min	0 L/min	0 L/min

<Air Flow Sensor D6FZ-FGS1000>

The status indication changes as shown below,

Air Flow Sensor Unit Status Indicator		Definition
(1)	Orange Blink	The air flow rate exceeds the upper threshold value.
(2)	Green ON	The air flow rate is normal and between the upper and lower threshold values.
(3)	Orange Slow Blink *1	The air flow rate exceeds the lower threshold value.
(4)	Green Slow Blink *2	The air flow rate is zero. The rate is within the lead detection flow rate range.
(5)	Deep Orange Blink	The air flows backward.

*1: In case of factory default setting, (3) does not occur because the lower threshold value and Leak Detection Flow Rate are both 0L/min

*2: When the value of Momentary Standard Flow is from -0.4 to 0.4L/min, the flow consider as zero. The measured result is in this range, the indicator shows (4).

Air Flow Sensor D6FZ-FGT□□□

It's possible to assign judgment of TH1-TH4 to 2 outputs. During output, display's output indicator is turned on. The output follows the output setting.

Momentary Flow value	Judgment conditions of the Air Flow sensor			
	TH1	TH2	TH3	TH4
(1)	Output	-	Output	Output
(2)	-	-	-	-
(3)	-	Output	Output	Output
(4)	-	Output	Output	-
(5)	Error Display (ERR-04)			

Air Flow Station D6FZ-FGX21

If the Air Flow Sensor measured value is more than Hi threshold, and between Cut and Lo threshold during RUN operation, the Air Flow Station's alarm output terminal turns ON and the "ALM" indication on the display turns ON.

If the measured value of any connected Air Flow Sensor unit is outside the threshold range, the alarm output terminal turns ON.

4.3.1 List of Setting Items

The table below shows the THR mode setting item list.

Display Item	Display	Setting Item	Function/Operation	Factory Default
NN.HI	nn.hi	Air Flow Sensor upper threshold value	Specifies the Air Flow Sensor upper threshold value for alarm output.	1000 L/min
NN.LOW	nn.lo	Air Flow Sensor lower threshold value	Specifies the Air Flow Sensor lower threshold value for alarm output.	0 L/min
NN.CUT	nn.cut	Leak detection flow rate	The threshold value for zero flow rate and specified between the lower threshold and zero flow rate values.	0 L/min
HOLD	hold	Alarm setting hold	Specifies if the alarm output is held when a measured value outside the upper and lower threshold range (Alarm status) returns to a normal value within the range during RUN operation.	OFF

4.3.2 Selecting Operation Mode

Press the MODE key to change the operation mode to "THR". "THR" at the lower right of the display starts blinking.

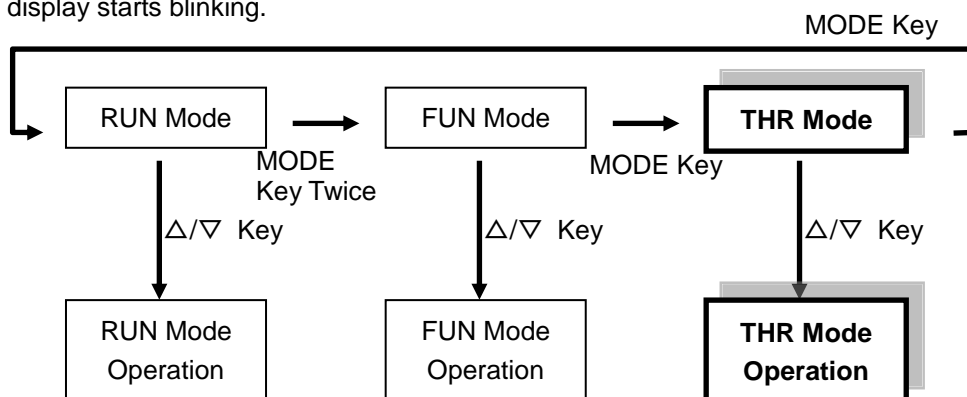

4.3.3 Selecting Items

To change the set value, select the item with Δ or ∇ key and apply the selection with the SET/REC/STOP key. Press the MODE key to change the operation mode. The unit resets itself and the setting is complete.

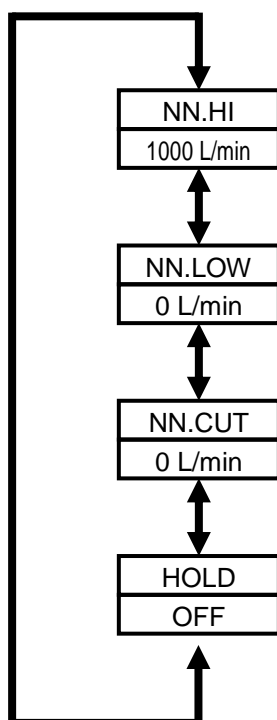

4.3.4 Description of Items

(1) Air Flow Sensor Upper Threshold Value (NN.HI)

Specifies the Air Flow Sensor upper threshold value.

The "ALM" indication and alarm output of the Air Flow Station unit turn ON, when the measured flow rate exceeds the set value. The status indication of the Air Flow Sensor changes.

D6FZ-FGS1000

The range of selection (Numeric input):

0 L/min to 1000 L/min (The threshold setting becomes OFF when both the upper and lower thresholds are set to 0)

Initial value:

1000 L/min

D6FZ-FGT500

The range of selection (Numeric input):

0 L/min ~ 500 L/min

Initial value:

250 L/min

D6FZ-FGT200

The range of selection (Numeric input):

0 L/min ~ 200 L/min

Initial value:

100 L/min

(2) Air Flow Sensor Lower Threshold Value (NN.LOW)

Specifies the Air Flow Sensor lower threshold value.

The "ALM" indication and alarm output of the Air Flow Station unit turn ON, when the measured flow rate falls below the set value. The status indication of the Air Flow Sensor changes.

D6FZ-FGS1000

The range of selection (Numeric input):

0 L/min to 1000 L/min

(The threshold setting becomes OFF when both the upper and lower thresholds are set to 0)

Initial value:

0 L/min

D6FZ-FGT500

The range of selection (Numeric input):

0 L/min ~ 500 L/min

Initial value:

250 L/min

D6FZ-FGT200

The range of selection (Numeric input):

0 L/min ~ 200 L/min

Initial value:

100 L/min

(3) Leak Detection Flow Rate (NN.CUT)

Specify the threshold value for zero flow rate. A value between the lower threshold and zero flow rate values must be specified.

If the specified threshold is exceeded, the status indication of the Air Flow Sensor changes.

D6FZ-FGS1000

The range of selection (Numeric input):

0 L/min to 1000 L/min

Initial value:

0 L/min

D6FZ-FGT500

The range of selection (Numeric input):

0 L/min ~ 500 L/min

Initial value:

0 L/min

D6FZ-FGT200

The range of selection (Numeric input):

0 L/min ~ 200 L/min

Initial value:

0 L/min

(4) Alarm Hold Setting (HOLD)

Specifies if the alarm output is held when a measured value outside the upper and lower threshold range (Alarm status) returns to a normal value within the range during RUN operation.

The range of selection (Options):

ON / OFF

Initial value:

OFF

4.3.5 Changing Set Value

Follow the same procedure as in FUN mode.

To change Air Flow Sensor set values, display the ID of the target Air Flow Sensor unit and enter THR mode.

(Refer to "4.2.5 Changing Air Flow Station Set Value" and "4.2.6 Changing Air Flow Sensor Set Value")

D6FZ-FGT□□□ displays "REMOTE" and key operations are not available.

When mode of the Air Flow Station is returned to RUN-mode, "REMOTE" is canceled.

5. Measurement and Recording (Air Flow Station Operation)

5.1 Overview

Measured values can be recorded in two ways: recording in Air Flow Station units or in the PC via network. This chapter explains recording in Air Flow Station units.

5.2 Selecting Operation Mode

RUN mode must be entered for air flow rate measurement.

Press the MODE key to change the operation mode to "RUN". "RUN" at the bottom right of the display turns ON.

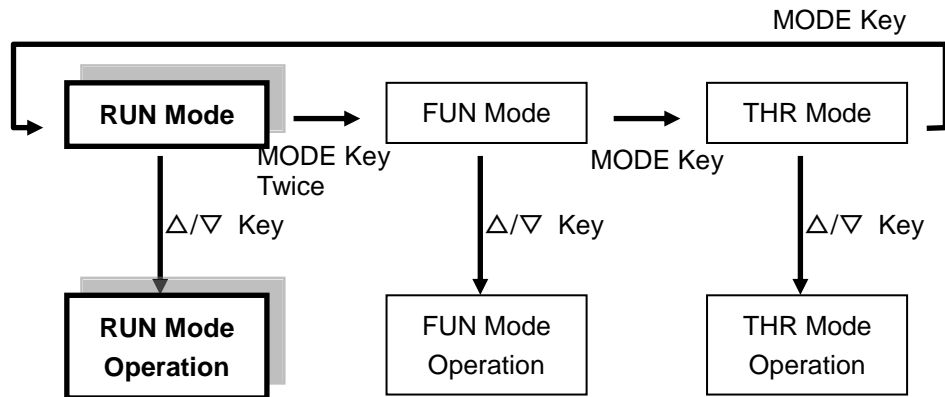

Note

Switching to other modes is prohibited during recording.

5.3 Screen Transition in RUN Mode

The following keys are used in RUN mode operation.

△ and ▽ Keys: Switch measured value display setting items in the sequence from Integrated Standard Flow Rate → Momentary Standard Flow Rate → Momentary Pressure → Momentary Temperature → Integrated Standard Flow Rate Converted Value.

△ Key Hold: Switches the Air Flow Sensor unit IDs.

MODE Key: Changes the operation mode.

The measurement display appears when RUN mode is entered. The following shows the configuration of the display.

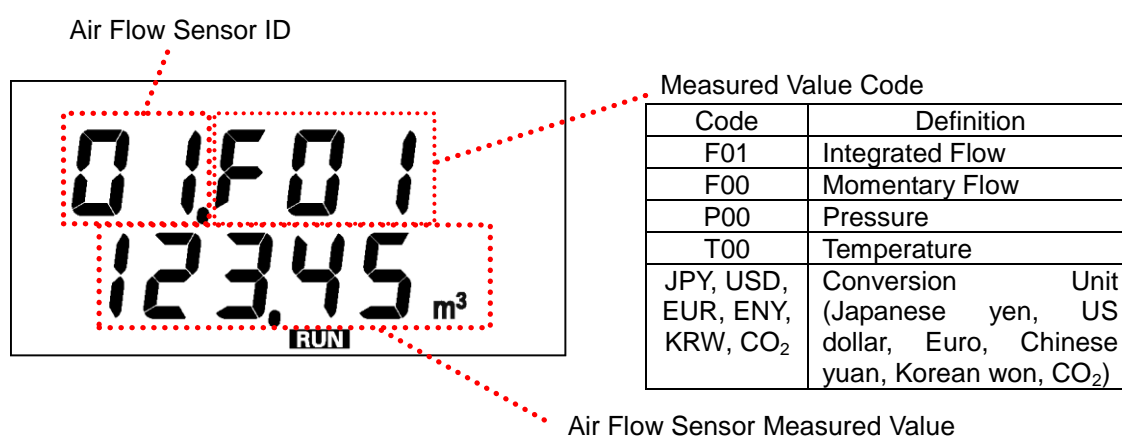

■Switching Measured Values

Pressing the △ or ▽ key switches measured values in the following sequence.

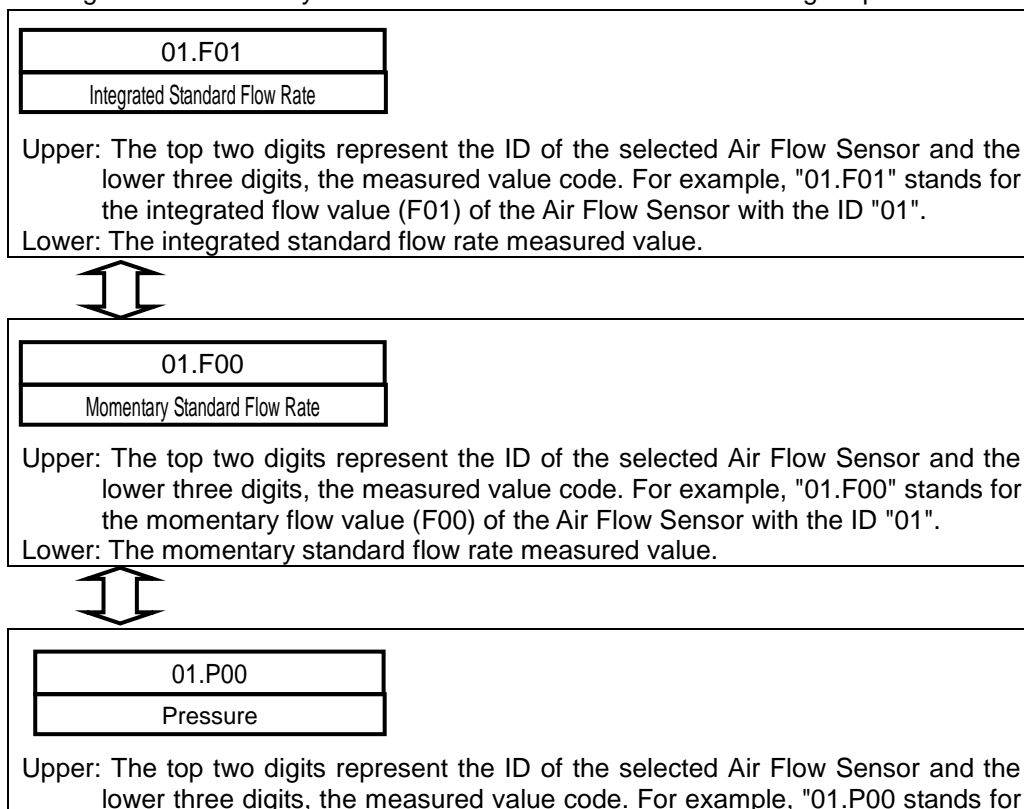

the pressure (P00) of the Air Flow Sensor with the ID "01".
 Lower: The pressure measured value.



01.T00
Temperature

Upper: The top two digits represent the ID of the selected Air Flow Sensor and the lower three digits, the measured value code. For example, "01.T00" stands for the temperature (T00) of the Air Flow Sensor with the ID "01".
 Lower: The temperature measured value.



01.JPY
Integrated Standard Flow Rate Converted Value

Upper: The top two digits represent the ID of the selected Air Flow Sensor and the lower three digits, the measured value code. For example, "01.JPY" stands for the converted value (JPY) of the Air Flow Sensor with the ID "01".
 Lower: The integrated standard flow rate converted value.



Returns to the first display.

Note: The momentary standard flow value is displayed in the unit specified in FUN mode.
 The integrated standard flow value is displayed in m³, pressure is in kPa,
 temperature is in °C.

* Pressure and Temperature are displayed only for D6FZ-FGS1000, "-----" is shown for D6FZ-FGT□□□.

■Switching Air Flow Sensor IDs

The following shows the procedure to switch the ID.

- A long press of the ∇ key in each measured value display switches the Air Flow Sensor IDs in the ascending sequence.
- During a long press of the key, the ID display is switched from one to another at the interval of 1 second.
- The integrated standard flow rate appears first whenever the ID is switched to another.

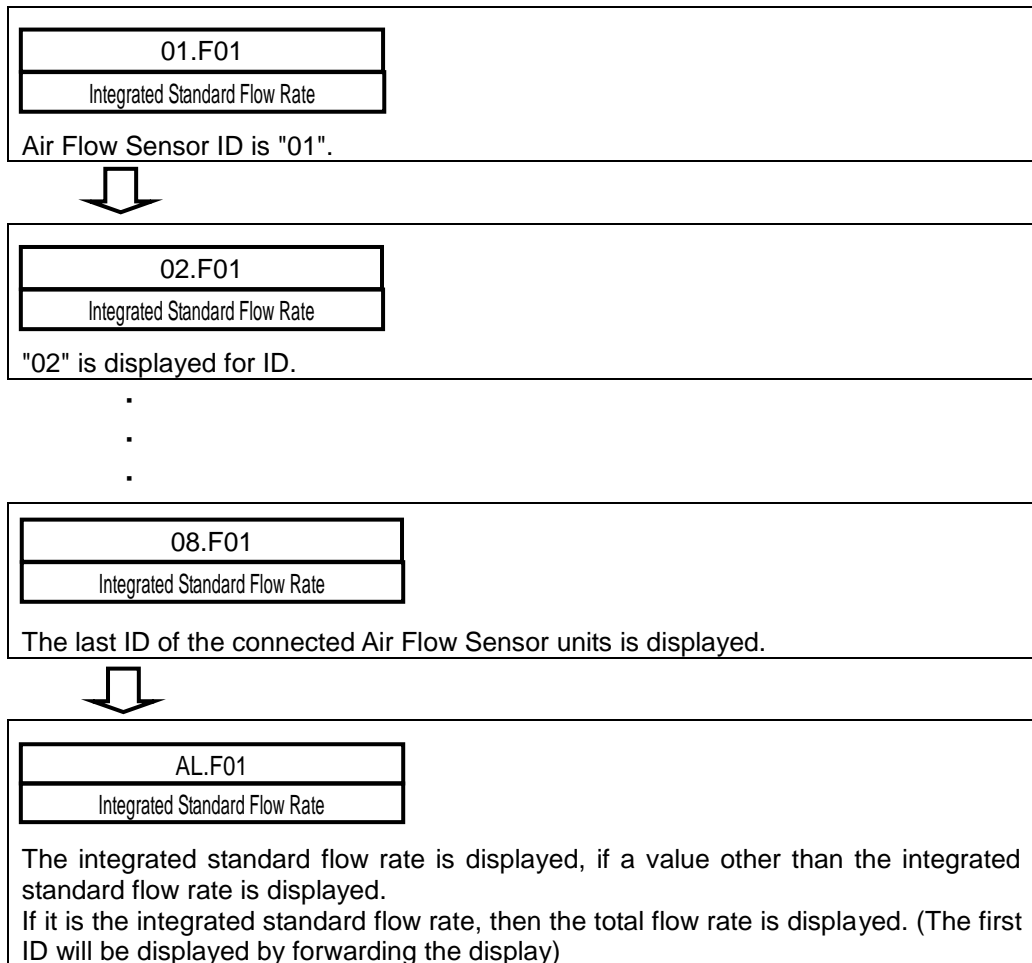

Note

- The "REC" indication turns ON during data recording.
- "ALM" turns ON when the measured value exceeds the upper and lower threshold range or the alarm output is ON. To cancel the retained alarm, hold the MODE key.

5.4 Starting/Stopping Recording

5.4.1 Starting Recording

Hold the SET/REC/STOP key (for at least 3 seconds) in RUN mode to start air flow data recording. The "REC" turns ON when recording starts.

The measured data is recorded and accumulated in the internal memory of the Air Flow Station unit, and is output in a CSV file to the SD memory card when the SET/REC/STOP key is pressed.

Important

- If recording starts with recorded data remaining in the internal memory, the remaining recorded data is lost. To save the data, press the SET/REC/STOP key for less than 3 seconds to output the data to the SD memory card before recording.
- The integrated standard flow rate of the Air Flow Sensor unit is initialized to 0m^3 when recording starts.

Note

- An SD memory card must be placed in the Air Flow Station unit when the SET/REC/STOP key is pressed for data output during recording, recording is stopped or the internal memory becomes full. It is not necessarily the case at the point when the unit starts recording.

Recording to the internal memory can be continued for the following:

The number of connected units is 1 and recording cycle is 1 second:

approx. 5200 data

The number of connected units is 8 and recording cycle is 2 seconds:

approx. 650 data

- Switching to other modes is prohibited during recording. Stop recording when other mode than RUN mode should be entered.

5.4.2 Stopping Recording

The Air Flow Station unit stops recording if the SET/REC/STOP key is held (for 3 seconds or longer) during recording (i.e. the "REC" is ON). The data in the internal memory is output to the SD memory card and "REC" turns OFF.

Important

- A write-enabled SD memory card must have been inserted in the slot when stopping recording. If a data output attempt fails, an error is output and recording is stopped without saving the data. To correct this, insert an SD memory card before resuming recording and press the SET/REC/STOP key to output the data.
- The data accumulated so far is discarded unless it is output before starting recording.

5.4.3 Auto backup and restarting record setting

When this function is ON in FUN mode, if power turns off during the record, the recorded measurement data before the interruption of power is backed up to SD memory card and record is resumed after power is back. And the recording restarts.

Important

While this function is ON, insert the recordable SD memory card into the SD memory card slot. If the SD memory card is not inserted at the time of power activation, the error which shows what the output to an SD memory card went wrong will be displayed, and record will stop.

5.5 Outputting File to SD memory card

Recorded data can be output to SD memory card files when any of the following cases happen.

- (a) The SET/REC/STOP is pressed (for less than 3 seconds) during recording.
Recording in the internal memory continues.
- (b) The SET/REC/STOP key is held (for 3 seconds or longer) during recording.
Recording in the internal memory stops.
(Refer to "5.4.2 Stopping Recording")
- (c) The internal memory becomes full during recording.
Recording in the internal memory continues.
(The recording mode must have been set to "Continue mode".)
(The factory default is set to "Continue mode". Use the provided PC software to switch the recording mode.)
- (d) The SET/REC/STOP key is pressed (for less than 3 seconds in RUN mode) during non-recording process, when recorded data remains in the internal memory.
- (e) The previously recorded data remains in the internal memory when the power is supplied.
This refers to the case that the unit restarts after it is reset during recording due to a power failure or the pressing of the reset switch.

5.6 Cancelling Alarm

"ALM" turns on when the measured value is more than Hi threshold range, and between Cut and Lo threshold, the alarm output turns ON.

To cancel the retained alarm, hold the MODE key (for 3 seconds or longer).

6. Appendix

6.1 Error Display List

■Air Flow Sensor (D6FZ-FGS1000)

Status Indicator	Description	Troubleshooting
Red Blink 100ms ON + 100ms OFF	System area non-volatile memory error	(1) There is a possibility that the air conditions for measurement have exceeded the detection feasible region of the sensor. Please change air conditions. Internal error can be considered when red blink continues after an alteration of condition. (2) These internal errors must be communicated to your sales representative, if the error is not solved by resetting the power supply.
Red Blink Repeat the cycle of 4 continuous blinks + 1 sec. OFF	Ultrasonic wave measurement error	
Red Blink Repeat the cycle of 3 continuous blinks + 1 sec. OFF	Pressure error	
Red Blink Repeat the cycle of 2 continuous blinks + 1 sec. OFF	Temperature error	
Red Continuous ON	Power outage detection	Check the power supply.

■Air Flow Sensor (D6FZ-FGT□□□)

Display	Error	Check Points
ERR-01 ERR-02	Internal Memory Error	Check about wiring : It may have been influenced from the high-tension wires or the power lines.
ERR-03 ERR-04	Sensor Error	Mounting direction : Whether it is fixed against the direction of an air flow.
		Air flow rate: Whether the air more than rating is flowing.
		Check about wiring: It may have been influenced from the high-tension wires or the power lines.

■Air Flow Station (D6FZ-FGX21)

Display	Description	Troubleshooting
DATA E1100	Measured data writing failure	Failed to write recorded data to the SD memory card due to no free space or the card being removed during writing. Insert a writable SD memory card. Hold the MODE key for 3 seconds or more to cancel the error display. If this error occurs, insert a normal SD memory card and stop recording. Resume recording after checking that the data has been normally written to the SD memory card.
SEN E22XX*	Child node integrated standard flow rate reset failure	The integrated standard flow rate reset notification is not output from the sensor unit with the relevant ID when recording starts. A break in connection or the discontinued power supply to the sensor unit may be the cause. Check the cable and reset the power supply. Holding the MODE key cancels the error display. Recording continues, but the integrated standard flow rate of the sensor where the error occurred is not reset.
SEN E23XX*	Child node setting parameter reading failure	Failed to read the setting parameters from the sensor unit whose setting is to be changed when the unit enters FUN mode. A break in connection, discontinued power supply to the sensor unit or replacement of the sensor with the power ON may be the cause. Check the cable and reset the power supply. Holding the MODE key cancels the error display. FUN mode operation continues, but the setting values of the sensor where the error occurred is not displayed.
SEN E24XX*	Child node setting value update failure	Failed to change the sensor setting values in FUN or THR mode. A break in connection or the discontinued power supply to the sensor unit may be the cause. Check the cable and reset the power supply. Holding the MODE key cancels the error display. FUN or THR mode operation continues, but the setting values of the sensor where the error occurred are not displayed.
SEN E25XX*	Sensor Error	Failed to read measured value from unit XX due to the sensor error. Remove the cause to error and hold the MODE key for at least 3 seconds to cancel the error. When recording at the time of error occurrence, record is also continued although the error is displayed. And measured data of unit XX is recorded as "ERR".

* "XX" indicates an ID of Air Flow Sensor.

Display	Description	Troubleshooting
UILCK E2800	Sensor mode changing failure	Failed to enter setting change mode of the air flow sensor (D6FZ-FGT□□□) to be changed. Hold the MODE key for at least 3 seconds to cancel the error, and switch to RUN mode by MODE key of the air flow sensor. Mode of the Air Flow Station needs to go back to RUN mode, too.
NO SD E3000	No SD memory card inserted	An SD memory card is not inserted. Insert a writable SD memory card. Hold the MODE key for 3 seconds or more to cancel the error display.
SDLOC E3002	Write-protected SD memory card	The SD memory card is write-protected. Replace it with a writable one. Hold the MODE key for 3 seconds or more to cancel the error display.
SD ER E3003	SD memory card recognition error	Failed to recognize the SD memory card. Insert a normal SD memory card. Hold the MODE key for 3 seconds or more to cancel the error display.
RESTR E5000	Invalid setting file data	The setting data in the SD memory card is invalid e.g. an invalid model type or setting values. Hold the MODE key for 3 seconds or more to cancel the error display.
BCKUP E5001	Setting file writing failure	Failed to write setting files to the SD memory card due to no free space or the card being write-protected. Insert a writable SD memory card. Hold the MODE key for 3 seconds or more to cancel the error display.
RESTR E5002	Setting file reading failure	There is no setting files contained in the SD memory card. Replace it with an SD memory card with setting files. Hold the MODE key for 3 seconds or more to cancel the error display.
HARD E8100, E8101, E8102, E8103, E8104	Hardware error	There may be a failure on the hardware. Please contact the distributor or OMRON representative office. The displayed error code is required for identifying the problem.

If an error not listed above occurs, it may be caused by the wrong wiring. Turn OFF the unit and check the wiring again.

6.2 Character Display List

<D6FZ-FGT□□□>

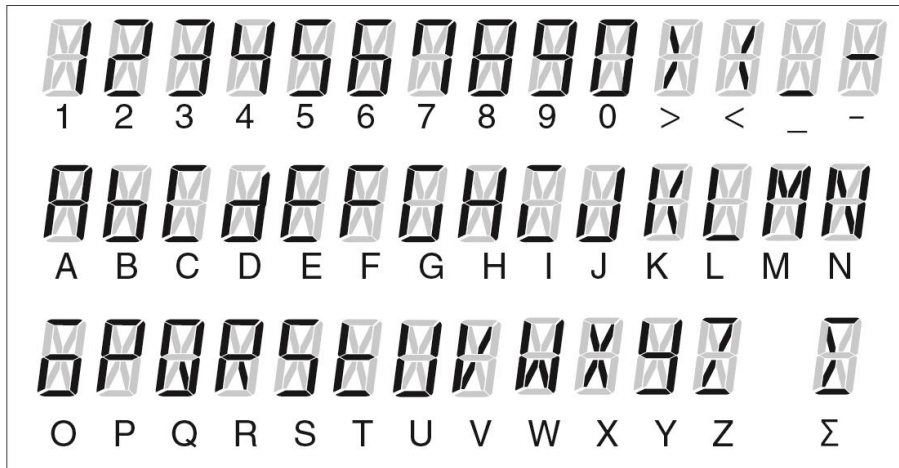

Display	String	Display	String	Display	String
PEK	PEK	UNT	UNT	STP	STP
b _t M	BTM	o _U T	OUT	TER	TER
H _L	HI	N _O /N _C	N.O/N.C	o _N	ON
LoW	LOW	PLS	PLS	o _{FF}	OFF
C _U T	CUT	S _C L	SCL	d _C SP	DISP
TYS	TYS	SER	SER	b _C T	BIT
ΣUP	ΣUP	EC _O	ECO	EVEN	EVEN
ΣLo	ΣLO	INIT	INIT	o _{DD}	ODD
ΣCLR	ΣCLR	U _{No}	U.No	N _o NE	NONE
AVE	AVE	BAU	BAU	o _K	OK
CYC	CYC	DA _T	DAT		
d _C R	DIR	PRTY	PRTY		

<D6FZ-FGX21>

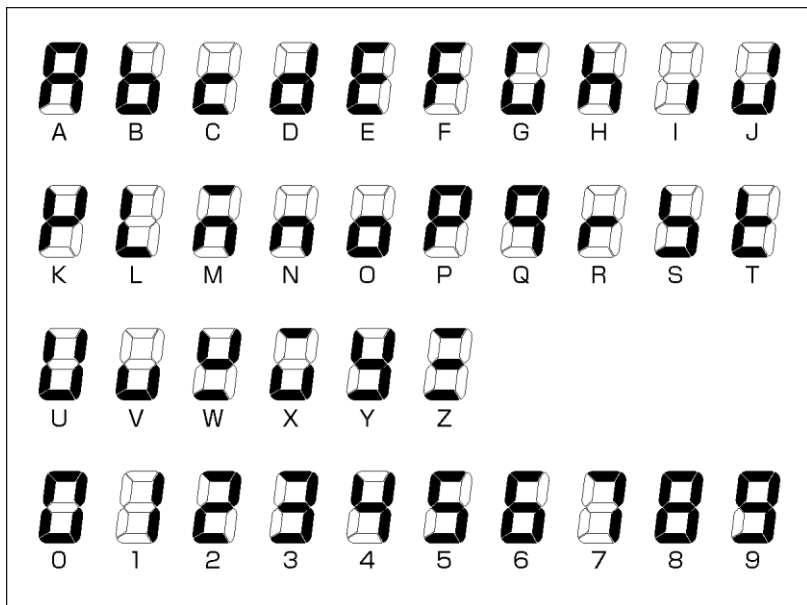

Display	String	Display	String	Display	String
cYcLE	CYCLE	ñoneth	MONTH	nn.LoY	NN.LOW
Un it	UNIT	dAY	DAY	nn.cUt	NN.CUT
in it	INIT	t inE	TIME	hoLd	HOLD
Etc	ETC	oFF	OFF	r inG	RING
nn.bEt	NN.SET	on	ON	rEset	RESET
nn.PLb	NN.PLS	d isP	DISP	donE	DONE
nn.bcl	NN.SCL	norñ	NORM	dAtA	DATA
nn.AvE	NN.AVE	,P	IP	SEn	SEN
nn.GAt	NN.GAS	Sub	SUB	no sd	NO SD
rEstR	RESTR	rAtE	RATE	sdLcP	SDLCK
bCpUP	BCKUP	conu	CONV	hARd	HARD
cLoCk	CLOCK	FUn it	FUNIT	toTAL	TOTAL
YEAr	YEAR	nn.h i	NN.HI		

Main Messages

6.3 SD Memory Card Folder Structure

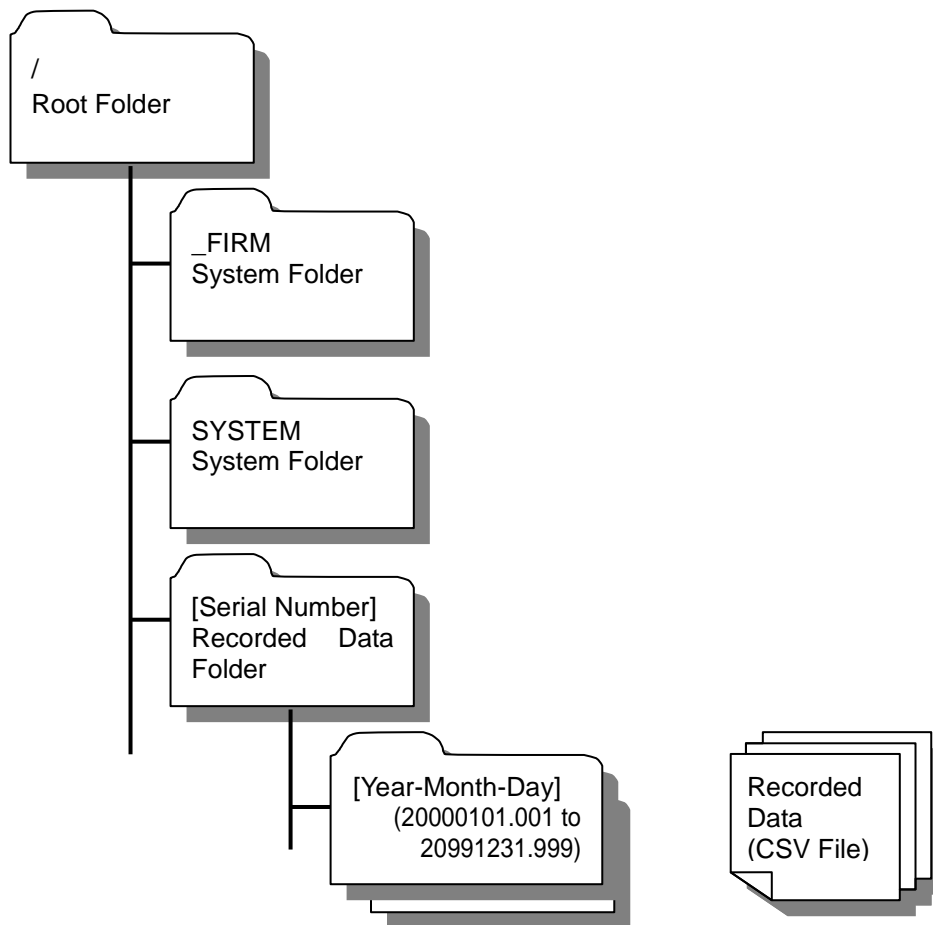

File/Folder Name	Description
_FIRM	For system use. Do not modify the file names or the internal files.
SYSTEM	For system use. Do not modify the file names or the internal files.
[Serial Number]	Folder for storing recorded data. The folders are named with the serial numbers corresponding to the Air Flow Station unit numbers.
[Year-Month-Day]	Sub folders for storing recorded data. Folder Name Structure: "Recorded time and date (YYYYMMDD format) + . + Serial No." Example: 20121001.001 The folder is written on October 1, 2012. Recorded data file is created in the CSV format. File Name Structure: "Hour-Minute-Second + Serial No.".CSV Example: 12345601.CSV The recorded data file is written at 12:24:56.

6.4 Calibration

Air Flow Station and Air Flow Sensor units do not required calibration.

Revision History

The specifications of this product are subject to changes without prior notice due to the addition of new functions or modification for improvement. These changes will be reflected in relevant manuals whenever such changes are made.

The revised manual contains the revision history with the manual revision codes and the revision descriptions.

Manual Revision Code

The manual revision code is provided at the lower right corner of the manual.

Rev. □

Revision Code

Revision History

Revision Code	Date	Description
Rev. A	November 2012	First edition.(Japanese)
Rev. B	August 2013	First edition.(English) Revised due to addition of new device and function.

OMRON Corporation Industrial Automation Company
Tokyo, JAPAN

Contact: www.ia.omron.com

Regional Headquarters

OMRON EUROPE B.V.

Wegalaan 67-69-2132 JD Hoofddorp
The Netherlands

Tel: (31)2356-81-300/Fax: (31)2356-81-388

OMRON ELECTRONICS LLC

One Commerce Drive Schaumburg,
IL 60173-5302 U.S.A.

Tel: (1) 847-843-7900/Fax: (1) 847-843-7787

OMRON ASIA PACIFIC PTE. LTD.

No. 438A Alexandra Road # 05-05/08 (Lobby 2),
Alexandra Technopark,
Singapore 119967

Tel: (65) 6835-3011/Fax: (65) 6835-2711

OMRON (CHINA) CO., LTD.

Room 2211, Bank of China Tower,
200 Yin Cheng Zhong Road,
PuDong New Area, Shanghai, 200120, China

Tel: (86) 21-5037-2222/Fax: (86) 21-5037-2200

Authorized Distributor:

© OMRON Corporation 2012 All Rights Reserved.
In the interest of product improvement,
specifications are subject to change without notice.