

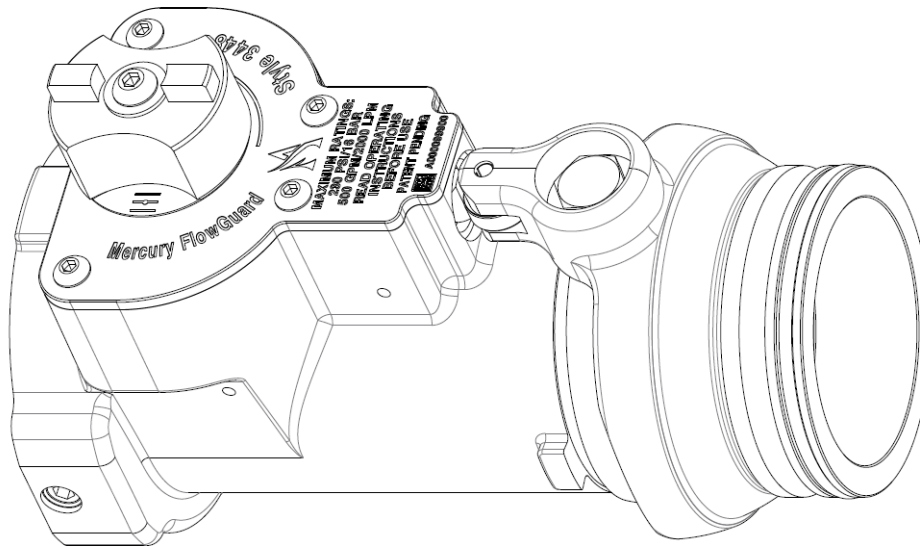

STYLE 3448 MERCURY FLOWGUARD™ INSTALLATION, OPERATING, AND MAINTENANCE INSTRUCTIONS

The following is intended to provide the basic instructions for installation, operation, and maintenance. Read and understand these operating instructions before use. **Note: This product is designed for the Style 3443 Mercury Quick Attack and Style 3444 Mercury Quick Attack and not for installation on any other monitor.**



PHONE: 330.264.5678 or 800.228.1161 | FAX: 330.264.2944 or 800.531.7335

www.akronbrass.com



STYLE 3448 MERCURY FLOWGUARD™ INSTALLATION, OPERATING, AND MAINTENANCE INSTRUCTIONS



Read and follow the operating instructions before use.



For firefighting use only.

Product Ratings

Mechanical Specifications:

Parameter	US Measure	Metric Measure
Flow Rate	500 GPM	1900 LPM
Pressure	230 PSI	16 Bar
Mass	4 lbs.	1.8 kg

Tools Required

- Medium flat screwdriver
- 3/16" Allen (hex) wrench
- O-ring lubricant
- Permabond LM113 thread locking liquid or equivalent

PHONE: 330.264.5678 or 800.228.1161 | FAX: 330.264.2944 or 800.531.7335

www.akronbrass.com



STYLE 3448 MERCURY FLOWGUARD™ INSTALLATION, OPERATING, AND MAINTENANCE INSTRUCTIONS

Product Warnings

	<ul style="list-style-type: none"> Indicates a hazardous situation which, if not avoided, WILL result in death or serious injury.
	<ul style="list-style-type: none"> Indicates a hazardous situation which, if not avoided, COULD result in death or serious injury.
	<ul style="list-style-type: none"> Indicates a potentially hazardous situation which, if not avoided, may result in minor or moderate injury.
	<ul style="list-style-type: none"> Addresses practices not related to personal injury.



- Not for use on electrical fires.
- Do not exceed the maximum pressure or flow rating of the monitor or FlowGuard assembly.
- Make sure both legs are fully deployed, all three spikes are in contact with the ground and safety strap is secure before use.
- Charge the unit slowly. Rapid charging may cause a pressure surge with the potential to cause injury or damage to the unit.
- Make sure the monitor is pointed in a safe direction before flowing water.
- The Mercury is supplied with a 2-1/2" ball valve. Open and close the valve slowly. Opening and closing the valve too quickly may result in damage to other equipment which can result in injury to the operator or others.
- Make sure the valve is closed when advancing the monitor. Do not move or lift the monitor while flowing.
- Read and follow the tip pressure and flows in the Mercury operating instructions before use.
- Inspect the Mercury ball valve for correct operation after each use.
- Inspect the Mercury rotation and elevation range after each use for proper movement. Inspect the inlet rotation joint on the FlowGuard mechanism along with the reset knob.
- During freezing conditions the monitor and FlowGuard must be drained to prevent damage.
- Do not use larger than a 3" hose.
- Replace any tags on the monitor or FlowGuard that have become worn or damaged.
- Do not apply any lubrication to the rotation/elevation outlet ball on the Mercury monitor.
- Your Mercury monitor assembly should be inspected prior to and after each use, to ensure it is in good operating condition. Periodically, an unanticipated incident may occur where the Mercury is used in a manner that is inconsistent with standard operating practices and those listed in IFSTA. A partial list of potential misuses follows:
 - Operating above maximum rated pressure and flow.
 - Not draining, and allowing water to freeze inside the nozzle or monitor.
 - Dropping the Mercury from a height where damage is incurred.

PHONE: 330.264.5678 or 800.228.1161 | FAX: 330.264.2944 or 800.531.7335

www.akronbrass.com



STYLE 3448 MERCURY FLOWGUARD™ INSTALLATION, OPERATING, AND MAINTENANCE INSTRUCTIONS

- Prolonged exposure to temperatures above +130 degrees F, or below -25 degrees F.
- Operating in a corrosive environment.
- Other misuse that might be unique to your specific firefighting environment.
- There are many “tell-tale” signs that indicate Mercury repair is in order, such as:
 - Controls that are inoperable or difficult to operate.
 - Excessive wear.
 - Poor discharge performance.
 - Water leaks.
- If any of the above situations are encountered, or other operating issues identified, the Mercury should be taken out of service and repaired, plus tested by qualified Mercury technicians, prior to placing it back in service.
- For use with fresh water or standard firefighting foams only. Not recommended for use with salt water. After use with foam or salt water, flush with fresh water.

NOTICE

Inlet FlowGuard Attachment

1. Remove existing swivel or existing other optional inlet connection (Storz, BIM, etc.) from the Mercury Quick Attack. Using a medium flat screwdriver unscrew the plastic ball bearing swivel plug in the side of the swivel. Remove the balls from the swivel. Do not discard the balls or swivel plug. There should be 38 balls removed from the MQA inlet swivel. Do not remove the O-ring that is underneath the swivel on the inlet of the MQA. Inspect the O-ring on the inlet for damage and replace if needed.
2. Installed on the inlet of the FlowGuard is a sealing O-ring (Fig. 1). Apply a small amount of lubricant to the O-ring.
3. Place the swivel over the inlet of the FlowGuard, install 38 balls into the hole in the side of the swivel and install the plastic swivel plug. The swivel should spin freely in both directions when finished. If the swivel does not spin freely, adjust the plastic swivel plug in or out as needed so the swivel spins freely without any binding.
4. In the outlet of the FlowGuard, a supplied O-ring contained in the operating instructions/parts list bag must be installed in the groove prior to placing on the inlet of the MQA (Fig. 1). Apply a small amount of O-ring lubricant before installation.
5. Insert one 3/8” socket head screw into the side of the FlowGuard housing a couple threads only (Fig. 1). This will keep the ball bearings from falling out the opposite side of the FlowGuard housing during mounting to the MQA inlet.

PHONE: 330.264.5678 or 800.228.1161 | FAX: 330.264.2944 or 800.531.7335

www.akronbrass.com

Figure 1

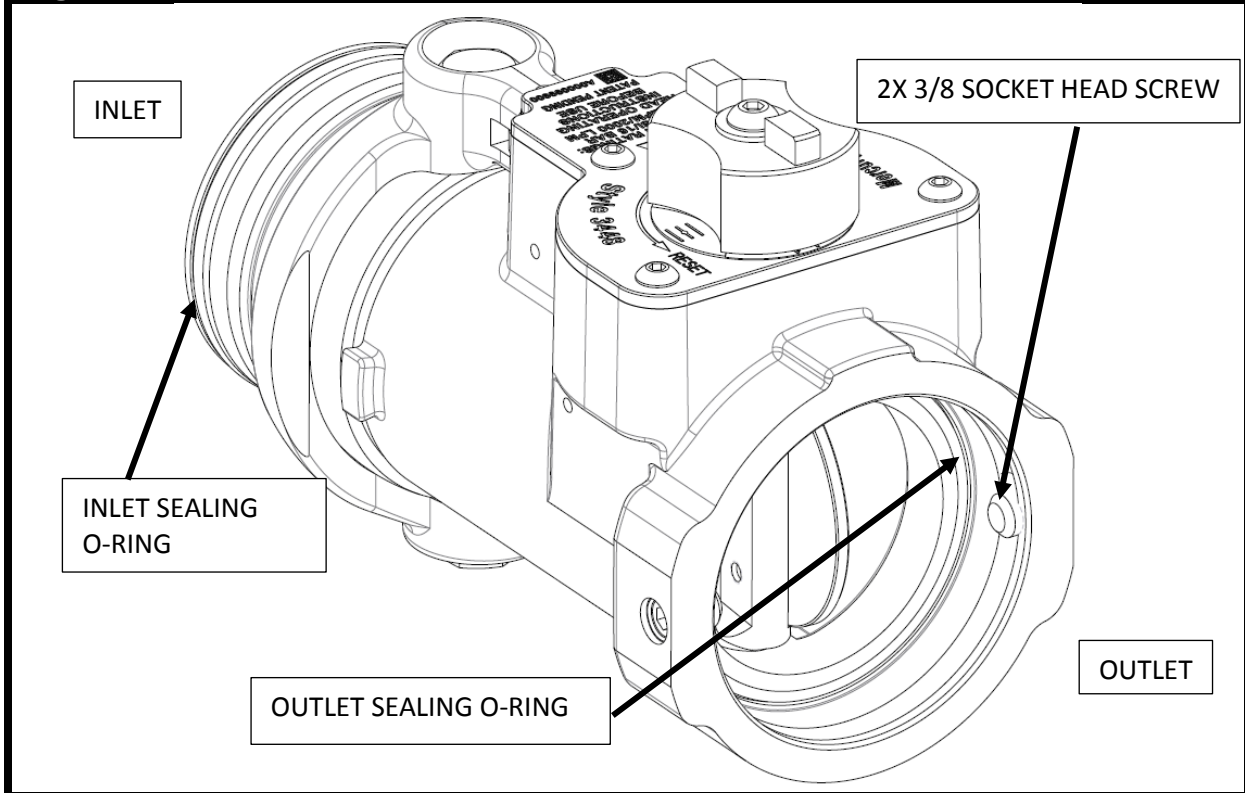

6. Slide the outlet of the FlowGuard assembly over the inlet of the MQA.
7. In the open 3/8" threaded hole in the side of the housing, install 36 ball bearings. A bag of 50 ball bearings and one plastic swivel plug is supplied with each assembly. There will be extra balls from the ball bearing bag remaining after assembly of the FlowGuard to the MQA is complete. This is normal. The plastic swivel plug may also not be needed during installation and is included as a spare.
8. Insert the other 3/8" socket head screw in the open hole. Make sure there are no ball bearings directly under the screw. This is best achieved by having the threaded hole pointing directly up. Turn the screw in until it bottoms in the ball bearing groove and then back out one turn.
9. Rotate the FlowGuard around so the first screw in step 5 is on top, remove the screw and make sure there are no ball bearings underneath the screw (Fig. 2). Insert the screw, turn in until it touches, then back out 1 turn.



STYLE 3448 MERCURY FLOWGUARD™ INSTALLATION, OPERATING, AND MAINTENANCE INSTRUCTIONS

Figure 2

INTERNAL END VIEW
SHOWING PLACEMENT
OF 3/8 SOCKET HEAD SET
SCREWS BETWEEN BALL
BEARINGS

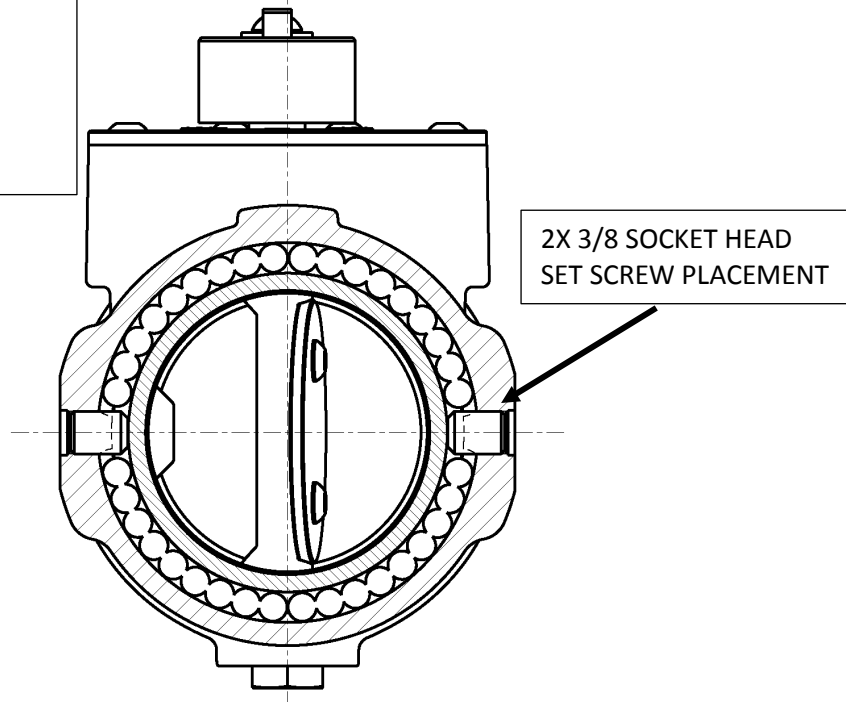

10. Rotate the FlowGuard assembly so the reset knob is on top and the raised boss on the housing is in line with the handle mount on the inlet of the MQA (Fig. 3).
11. Apply PermaBond LM113 thread locking liquid or equivalent to each screw and completely tighten each 3/8" socket head set screw using a 3/16" hex wrench into the ball bearing groove beneath.
12. The assembled flow reducer should conform to Fig. 3. **Warning: The FlowGuard must be oriented as show in Fig. 3. If oriented otherwise, the FlowGuard will not work as designed creating a potential hazard.**

Figure 3

PHONE: 330.264.5678 or 800.228.1161 | FAX: 330.264.2944 or 800.531.7335

www.akronbrass.com



STYLE 3448 MERCURY FLOWGUARD™ INSTALLATION, OPERATING, AND MAINTENANCE INSTRUCTIONS

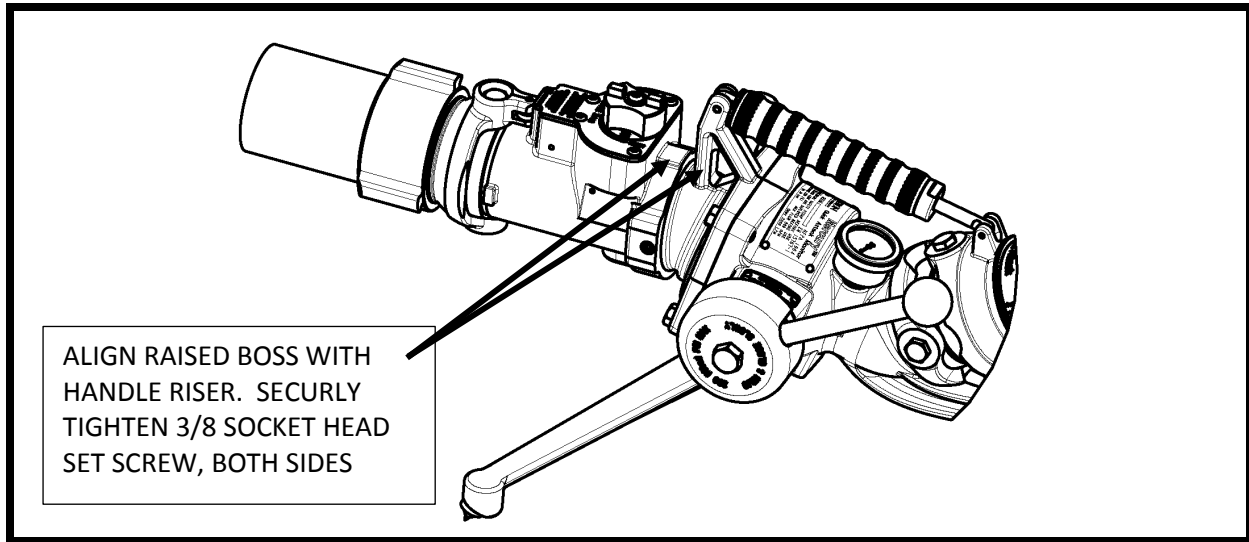

Inlet FlowGuard and Monitor Setup and Operation

1. Place the MQA monitor assembly on the ground with legs extended and the tie down strap secured to a solid object.
2. Attach the supply hose to the inlet of the MQA assembly. The hose must be in line with the MQA.
3. With the shutoff valve on the MQA open, slowly charge the MQA. When flow is established readjust the inlet hose and monitor as needed to straighten the system. During flow initiation the FlowGuard mechanism may activate. Reset the system as outlined in step 5 below. Final setup of the MQA system is shown in Figure 4.

Figure 4

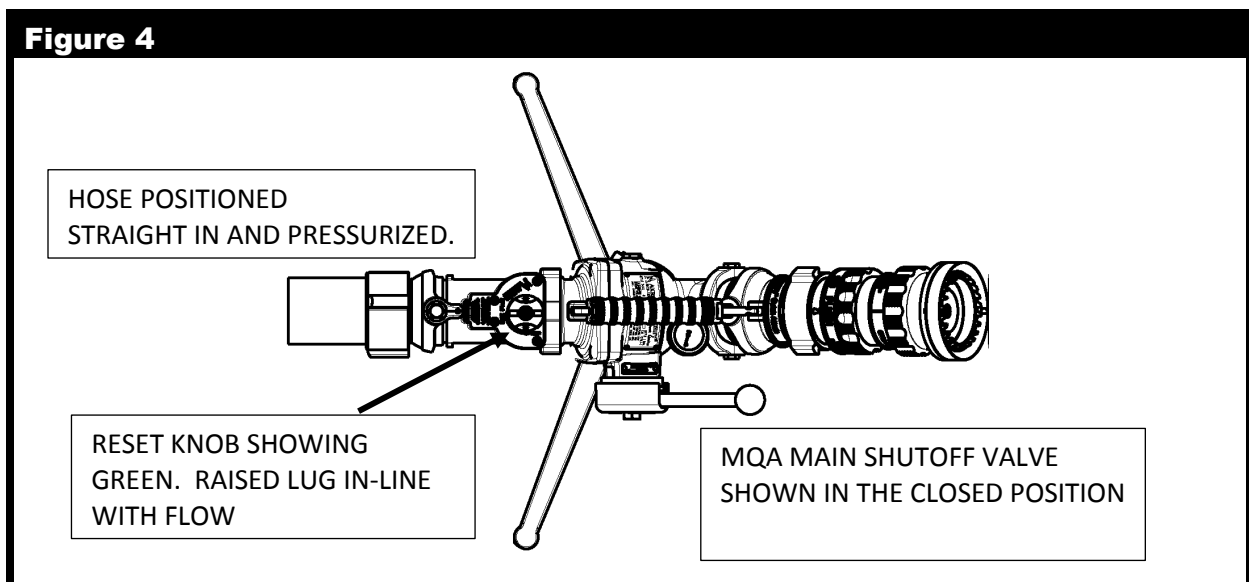

4. The inlet FlowGuard operates when the MQA has any motion in the opposite direction of flow. As the MQA moves backwards the inlet of the FlowGuard mechanism rotates around a pivot point and mechanically releases the internal disk which closes and restricts flow. **Note: flow is not completely shutoff but is significantly reduced which decreases the reaction force and allows the MQA to become stable.**

PHONE: 330.264.5678 or 800.228.1161 | FAX: 330.264.2944 or 800.531.7335

www.akronbrass.com



STYLE 3448 MERCURY FLOWGUARD™ INSTALLATION, OPERATING, AND MAINTENANCE INSTRUCTIONS

5. Indicators the FlowGuard mechanism has been activated.
 - a. Significantly reduced flow and reduced reach.
 - b. The stream is not on the original down range target.
 - c. Increased pressure and reduced flow at the pump.
 - d. Rotation joint at the inlet of the FlowGuard is approximately 20 degrees to the left or right of the monitor inlet.
 - e. The reset knob raised lug is 90 degrees to the water flow path.
 - f. Red and not green is seen around the reset knob. Symbol in the red is that of a partially closed butterfly disk.
 - g. Figure 5 depicts a MQA in which the FlowGuard mechanism has activated.

Figure 5

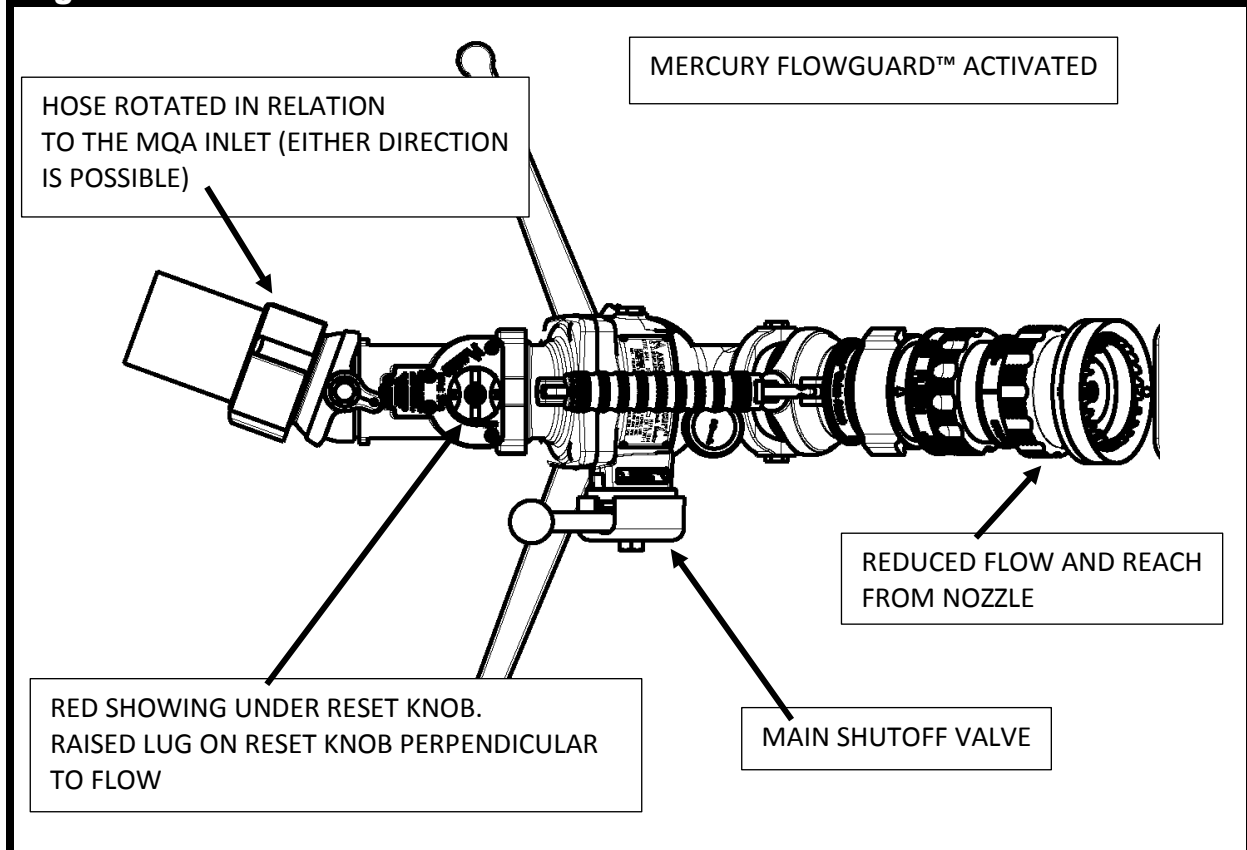

6. To reset the system follow the steps below:
7. Close the main shutoff valve on the MQA.
8. Rotate the reset knob on top of the FlowGuard assembly in the direction of the arrow (counterclockwise) so the raised lug is in line with the water flow path and green is seen around the knob. The symbol in the green is that of an open butterfly disk.
9. Reposition the MQA as needed for required direction of flow and down range target.
10. Straighten the inlet of the FlowGuard so the inlet and hose are in line with the MQA. The hose may require being pulled away from the MQA to assist in straightening of the inlet. Figure 4 shows a properly reset MQA with the Mercury FlowGuard attachment.
11. Slowly open the main shutoff valve on the MQA, adjusting the inlet hose as needed to keep the hose and inlet straight into the FlowGuard.
12. Increase flow to the MQA as needed whether using the main shutoff valve or increasing flow via the pump to reestablish required flow to the system.

PHONE: 330.264.5678 or 800.228.1161 | FAX: 330.264.2944 or 800.531.7335

www.akronbrass.com



STYLE 3448 MERCURY FLOWGUARD™ INSTALLATION, OPERATING, AND MAINTENANCE INSTRUCTIONS

Maintenance Instructions

- After use, flush the MQA, FlowGuard and nozzle with clean water to clean grit and dirt from around exterior moving parts. Doing so will allow the system to operate as designed.
- Over time the seals may need replaced. This can be accomplished by purchasing the appropriate Akron Brass repair kit. Use qualified maintenance mechanics or return the unit to Akron Brass for repair.
- Use low temp Lubriplate on metal parts and Parker O-Ring lubricant on O-Rings unless otherwise directed on the parts list supplied with the product.

PHONE: 330.264.5678 or 800.228.1161 | FAX: 330.264.2944 or 800.531.7335

www.akronbrass.com



STYLE 3448 MERCURY FLOWGUARD™ INSTALLATION, OPERATING, AND MAINTENANCE INSTRUCTIONS

Warranty Statement

WARRANTY AND DISCLAIMER*: We warrant Akron Brass products for a period of five (5) years* after purchase against defects in materials or workmanship. Akron Brass will repair or replace product which fails to satisfy this warranty. Repair or replacement shall be at the discretion of Akron Brass. Products must be promptly returned to Akron Brass for warranty service. We will not be responsible for: wear and tear; any improper installation, use, maintenance or storage; negligence of the owner or user; repair or modification after delivery; failure to follow our instructions or recommendations; or anything else beyond our control. WE MAKE NO WARRANTIES, EXPRESS OR IMPLIED, OTHER THAN THOSE INCLUDED IN THIS WARRANTY STATEMENT, AND WE DISCLAIM ANY IMPLIED WARRANTY OF MERCHANTABILITY OR FITNESS FOR ANY PARTICULAR PURPOSE. Further, we will not be responsible for any consequential, incidental or indirect damages (including, but not limited to, any loss of profits) from any cause whatsoever. No person has authority to change this warranty. Unless otherwise provided herein. Akron Brass industrial electronic components & the Severe-Duty Monitor have a one (1) year warranty. Select Akron Brass handline nozzles and valves carry a ten (10) year warranty. Weldon products have a two (2) year warranty from date of manufacture (excluding consumable components). Select Weldon LED products carry a five (5) year warranty. Honda products have the manufacturers' warranty and Akron Brass disclaims any warranty in respect of those products.

PHONE: 330.264.5678 or 800.228.1161 | FAX: 330.264.2944 or 800.531.7335

www.akronbrass.com



**STYLE 3448 MERCURY FLOWGUARD™
INSTALLATION, OPERATING, AND MAINTENANCE INSTRUCTIONS**

Revision History

Revision	Reason Updated
2/7/2019	New Instruction
12/12/19	Added FlowGuard product name.

PHONE: 330.264.5678 or 800.228.1161 | FAX: 330.264.2944 or 800.531.7335

www.akronbrass.com