



Cruzber S.A., ES-A14018311
P.I. Las Salinas II, E-14960 Rute
www.cruzber.com

- (E)** Instrucción de montaje
¡Leer primero!
- (GB)** Assembly instructions
Read first!
- (F)** Instruction de montage
Lire en premier!
- (D)** Montageanleitung
Zuerst lesen!
- (PT)** Instruções de montagem
Ler primeiro!
- (PL)** Instrukcja montażu
Najpierw przeczytaj!
- (CZ)** Montážní návod
Čtěte pozorně!
- (HU)** Szerelési Utasítás
Először olvassd el!
- (RO)** Instrucțiuni de montaj
Întai citiți!
- (HR)** Detaljne upute
Prvo pročitati!
- (GR)** Διαβάστε προσεκτικά τις
Οδηγίες Συναρμολόγησης!
- (TR)** Öncelikli montaj:
Talimatlarını okuyunuz!
- (RU)** Инструкции по монтажу
Сначала прочитайте!
- (IT)** Istruzioni di montaggio
Leggere per primo!
- (NL)** Montagehandleiding
Eerst lezen!
- (SLO)** Navodila za sestavljanje
Preberite!

- Barras de acero
- Steel bars
- Barres d'acier
- Stahldachträger
- Barras d'aço
- Belki stalowe
- Ocelové strešní nosiče
- Acél rudak
- Čelične šipke
- Bare din otel
- Μπάρες Σιδερέ
- Çelik barlar
- Стальные поперечины
- Barre d'acciaio
- Stalen dakdragers
- Jeklene prečke

Código Code Code Kode	921- 3xx								
Lv 7 2013 - r7									
Modelo Model Modèle Modell	SX								
Lote Lot Lot Lot	<table border="1" style="display: inline-table; border-collapse: collapse; text-align: center;"> <tr><td> </td></tr> <tr><td> </td></tr> <tr><td> </td></tr> <tr><td> </td></tr> </table> Peso Weight Poids Gewicht <table border="1" style="display: inline-table; border-collapse: collapse; text-align: center;"> <tr><td> </td></tr> <tr><td> </td></tr> <tr><td> </td></tr> <tr><td> </td></tr> </table>								
Max: 75 kg									
Código Homologación CEE EEC Type Approval Number e9*74/483*87/354*3017									

1°
2°

- (E)** Contenido embalaje: ¡Verificar!
- (GB)** Package content: Check!
- (F)** Contenu d'emballage: Vérifier!
- (D)** Packungsinhalt: Überprüfen!
- (PT)** Contéudo embalagem: Verificar!
- (PL)** Zawartość opakowania: sprawdź!
- (CZ)** Obsah balení: Zkontrolujte!
- (HU)** Csomag tartalma: Ellenőrizd!
- (RO)** Pachetul contine: Verificati!
- (HR)** Sadržaj paketa: Provjeri!
- (GR)** Ελέγξτε το περιεχόμενο: του πακέτου!
- (TR)** Paket içeriğini: Control ediniz!
- (RU)** Содержание упаковки: Проверьте!
- (IT)** Contenuto della confezione: Controllare!
- (NL)** Pakket inhoud: Controleer!
- (SLO)** Vsebina paketa: Preverite!

x 1 	x 1 	x 2 	x 2 Bag (853-051)
---------	---------	---------	------------------------------------

Código Code				Lote Lot
921-355	SX-110 (822-008)	110 cm	4,25 kg	02/12
921-360	SX-120 (822-018)	120 cm	4,50 kg	02/12
921-365	SX-130 (822-028)	130 cm	4,75 kg	02/12

Código
Code
Code
Kode

921-3xx

Lv 7 2013 - r7

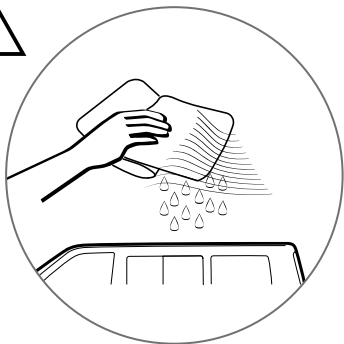

Importante!
Important!
Important!
Wichtig!

- E** Estas barras tienen que usarse con Kits de fijación Cruz!
- GB** Bars must be used with Cruz fixation Kits!
- F** Les barres devront être utilisées avec les Kits de fixation Cruz!
- D** Die Dachlsträger nur mit Cruz Stützfuß-Kits befestigen!
- PT** As barras devem ser utilizadas com os Kits de fixação Cruz!
- PL** Belki muszą być stosowane z elementami mocującymi firmy Cruz!
- CZ** Tento nosič musí být používán s fixačním kitem Cruz!
- HU** A rudákat csak Cruz rögzítő készlettel szabad használni!
- RO** Barele trebuie utilizate cu Kit-uri de fixare Cruz!
- HR** Šipke moraju biti korištene sa Cruz kitovima za montažu!
- GR** Το αξεσουάρ αυτό θα πρέπει να χρησιμοποιείται αποκλειστικά στα συστήματα μπαρών της Cruz!
- TR** Bu barlar mutlaka Cruz montaj kiti!
- RU** Поперечины должны быть использованы со специальным крепежным комплектом Cruz!
- IT** Questa bare deve essere utilizzato solo con il kit di fissaggio Cruz!
- NL** Dakdragers moeten worden gebruikt in combinatie met de bevestigingssets van Cruz!

1

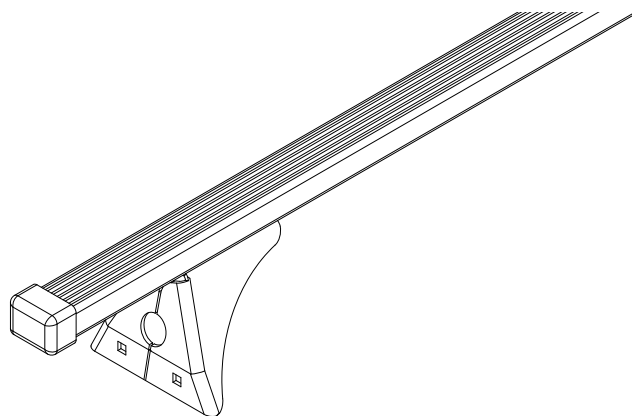

2

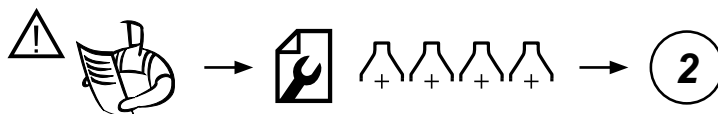

3

